



January 2026

Monumental Core Streetscape Construction Manual

Contents

Introduction	3
Sidewalks, Paving, and Surfaces	4
Exposed Aggregate Sidewalk	5
Concrete Sidewalk (DC).....	6
Concrete Paver Sidewalk (DC).....	7
Brick Sidewalk (DC)	8
PADC Paver Sidewalk.....	9
Exposed Aggregate Concrete Step Out Curb	10
Sidewalk Surfaces.....	11
Bus Pad	12
Wheel Chair Ramps	14
Porous Asphalt.....	17
Driveway Apron	19
Concrete Median	21
Separated Bikelane.....	23
Curbs and Gutters.....	25
Granite Curbing.....	26
Bluestone Curbing	28
Curb Inlet and Gutter.....	29
Asphalt Gutter	31
Brick Gutter	33
Plantings, Soils, and Bioretention.....	35
Tree Planting	36
Tree Maintenance	40
Tree Box Treatments	42
Structural Soil.....	50
Bioretention Planter	53
Street Tree Fence.....	55
Lighting	60
Twin-Twenty	61
Washington Globe.....	62
Frederick Law Olmsted	64
Light Standard Specifications	65
Furnishings and Civic Infrastructure.....	68
Waste Receptacles.....	69
Benches.....	71
Drinking Fountain.....	73
Post & Chain	74
Bicycle Rack	74
Parking Pay Station	75
Other.....	75

Introduction

The Streetscape Construction Manual, part of the larger **Monumental Core Streetscape Guide and Construction Manual**, includes construction details and specifications for streetscape elements within the monumental core. Some specifications are performance-based, while others are prescriptive. It is most useful to landscape architects, facilities managers, and construction workers when planning, constructing, and maintaining streetscape projects.

See the Monumental Core Streetscape Guide and Construction Manual: Introduction Chapter for more information on project background and purpose; goals and priorities; use, applicability, and administration; and implementation. The Construction Manual is a living document and can have details and specifications amended or added as construction best practices shift or new detail types are needed. The Introduction Chapter also contains information on the Interagency Working Group process for amending or adding details and/or specifications.

Disclaimer

The details and specifications within this document are for informational purposes only and are not intended to be used for construction. Agencies and their consultants should use these details and specifications as a foundation in their design and construction processes and adjust as required to ensure their appropriateness for each project and site. Agencies and their consultants are responsible for confirming individual projects meet all applicable laws, regulations, and standards and receiving all necessary permits or approvals.

Sidewalks, Paving, and Surfaces

EXPOSED AGGREGATE SIDEWALK DETAIL

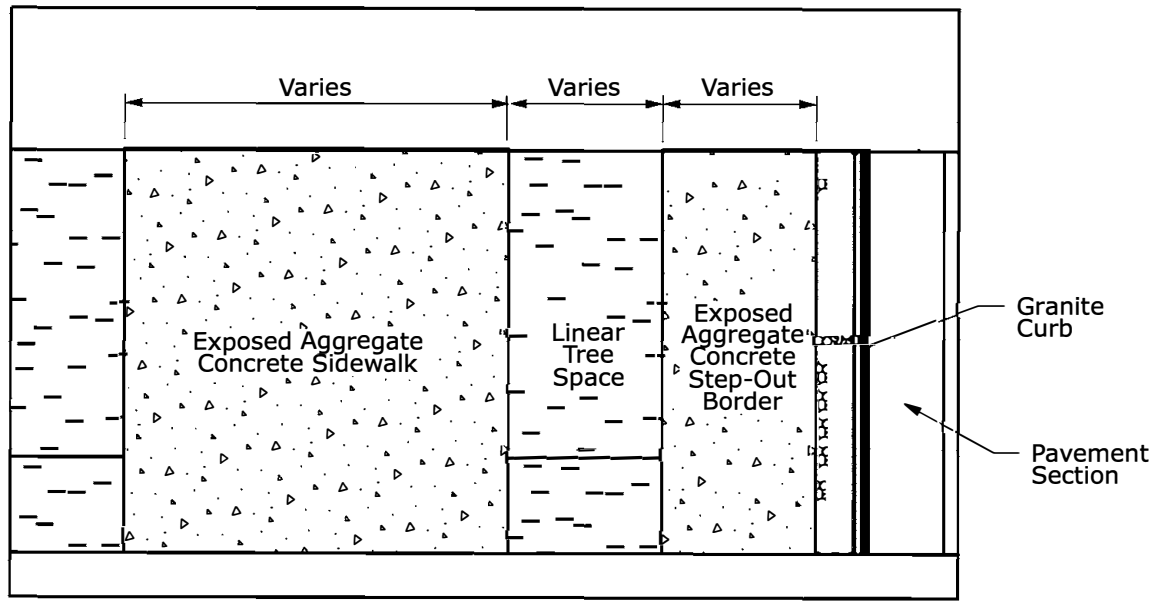

TOP VIEW

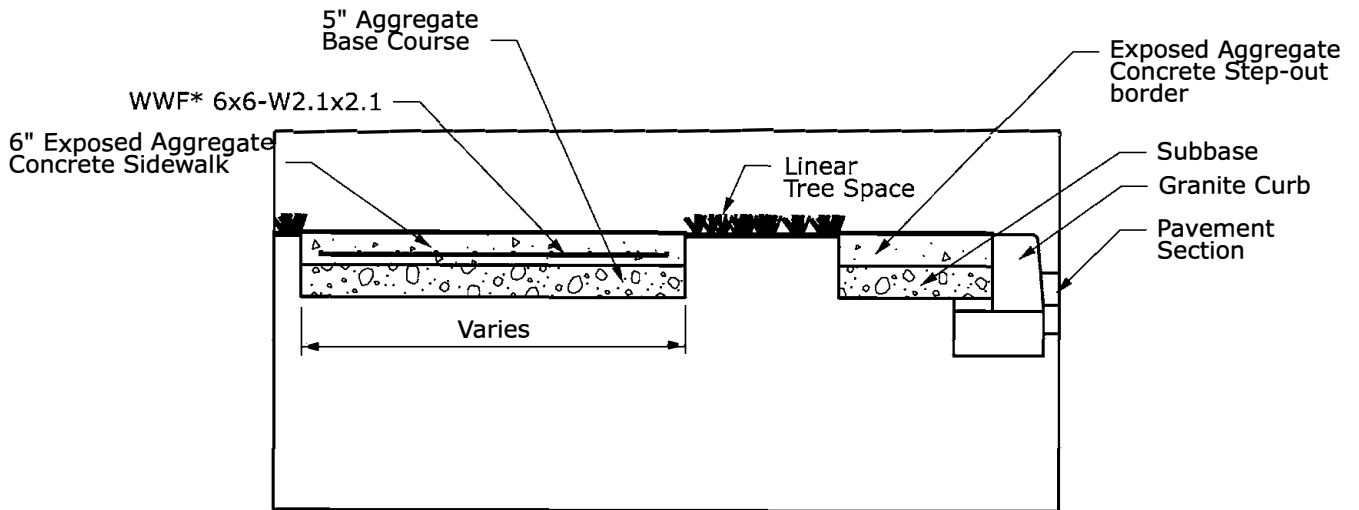

SECTION VIEW

* Welded Wire Fabric

NOTE

1. For Step-Out Border, see Exposed Aggregate Concrete Step-Out Border detail.

No Scale

**EXPOSED AGGREGATE
CONCRETE SIDEWALK**

CONCRETE SIDEWALK (DC) DETAIL

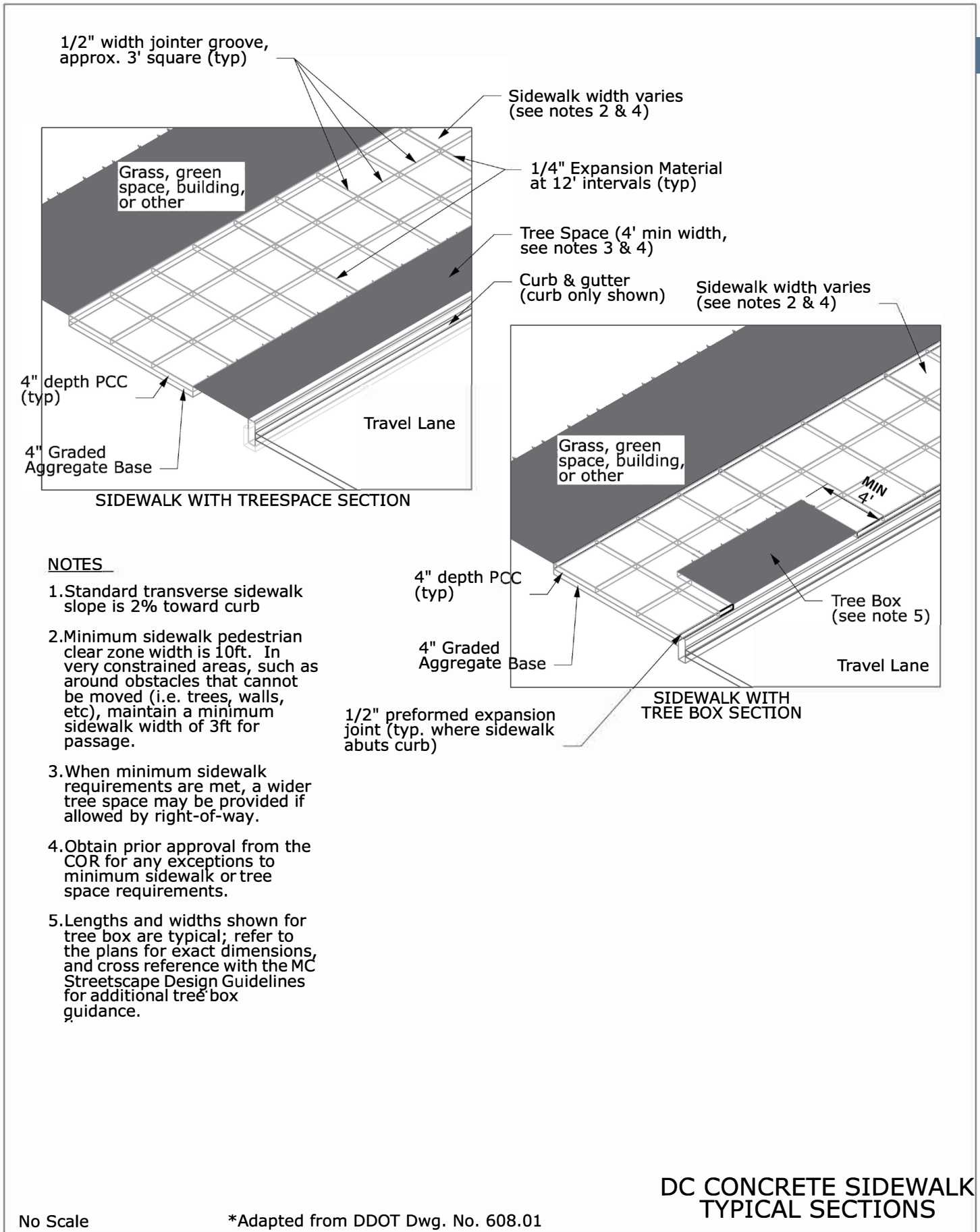

CONCRETE PAVER SIDEWALK (DC) DETAIL

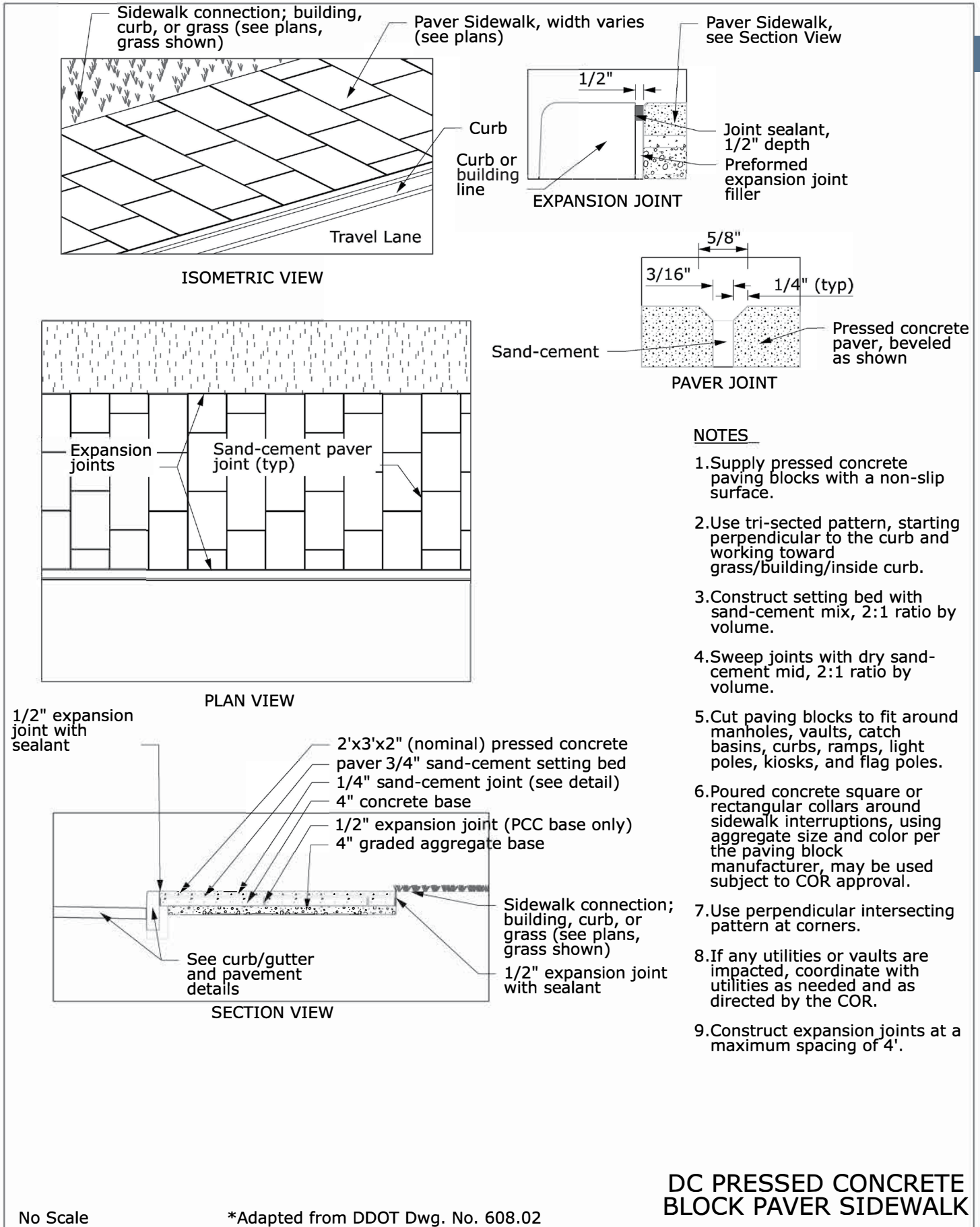

No Scale

*Adapted from DDOT Dwg. No. 608.02

BRICK SIDEWALK (DC) DETAIL

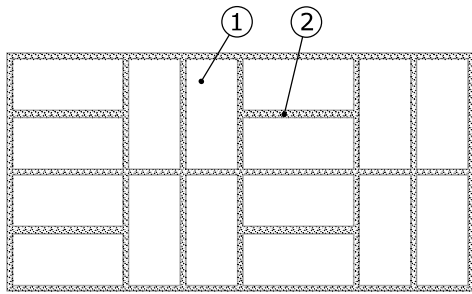
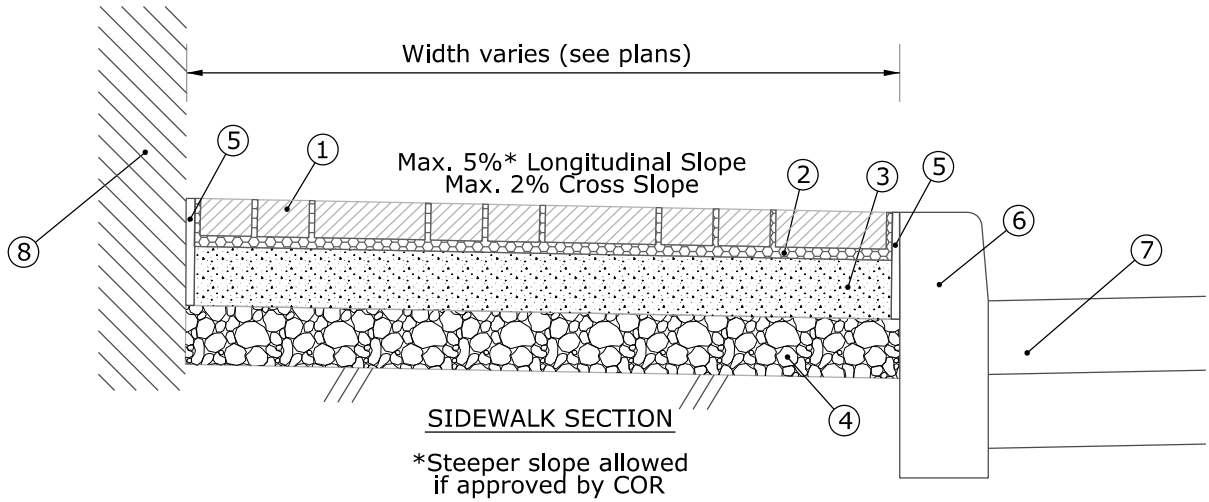

BASKET WEAVE PATTERN

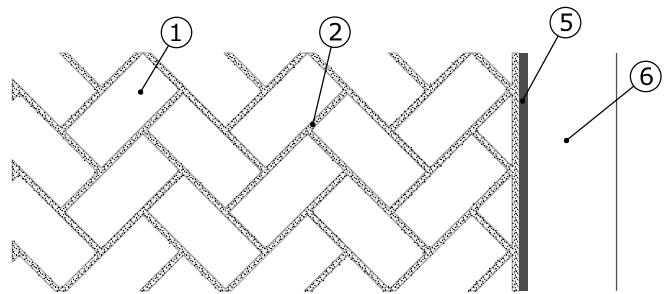

HERRINGBONE PATTERN

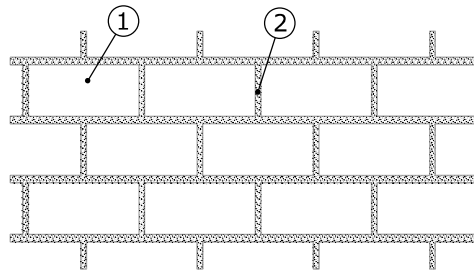

BISECTING PATTERN

LEGEND

- ① Brick, 7.5" x 3.5" x 3.5"
- ② 3/4" compacted mortar bed (dry mix)
- ③ 4" Portland Cement Concrete (PCC) base
- ④ 4" graded aggregate base
- ⑤ 1/2" preformed expansion joint
- ⑥ Curb
- ⑦ Travel lane
- ⑧ Building, wall, curb, or other

NOTES

1. Construct brick pattern as shown in the plans and at the direction of the COR.

DC BRICK SIDEWALK

No Scale

*Detail adapted from DDOT DWG. No. 608.04 and 608.05

PADC PAVER SIDEWALK DETAIL

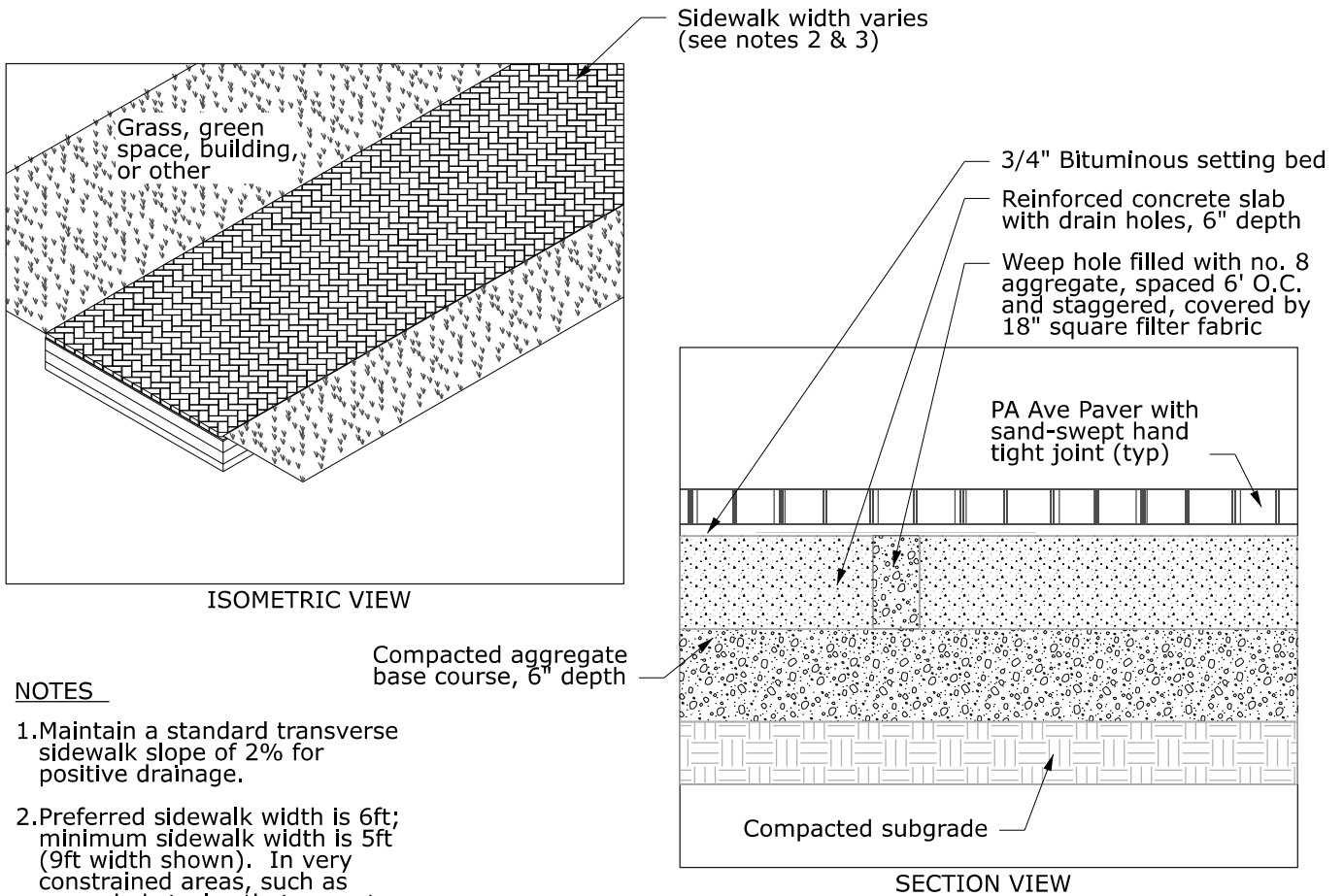

NOTES

1. Maintain a standard transverse sidewalk slope of 2% for positive drainage.
2. Preferred sidewalk width is 6ft; minimum sidewalk width is 5ft (9ft width shown). In very constrained areas, such as around obstacles that cannot be moved (i.e. trees, walls, etc), maintain a minimum sidewalk width of 3ft for passage.
3. Obtain prior approval from the COR for any exceptions to minimum sidewalk requirements.
4. Where sidewalk abuts curb or other rigid features, cut bricks to fit and construct 1/2" preformed expansion joints between the concrete slab and the abutting feature (not shown, see DC CONCRETE SIDEWALK TYPICAL SECTIONS).
5. Place 1/4" expansion material at 4' intervals in the concrete slab (not shown, see DC CONCRETE SIDEWALK TYPICAL SECTIONS).
6. Place bricks in a Herringbone pattern as shown in the plans and as directed by the COR.

PENNSYLVANIA AVENUE DEVELOPMENT CORPORATION (PADC)
PAVER SIDEWALK

No Scale

EXPOSED AGGREGATE CONCRETE STEP OUT CURB DETAIL

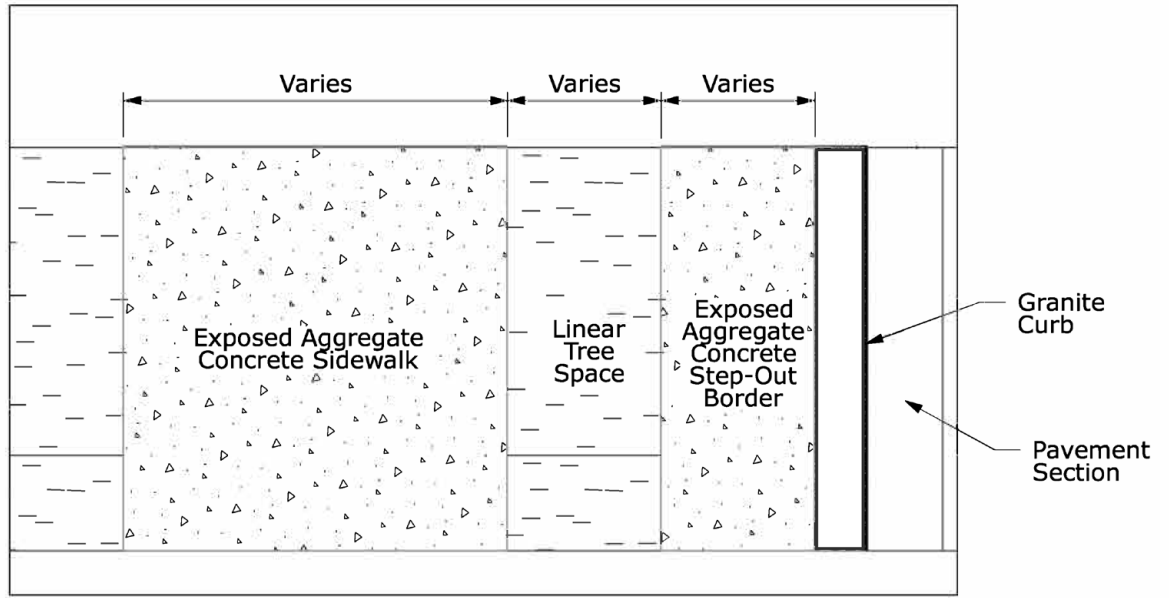

TOP VIEW

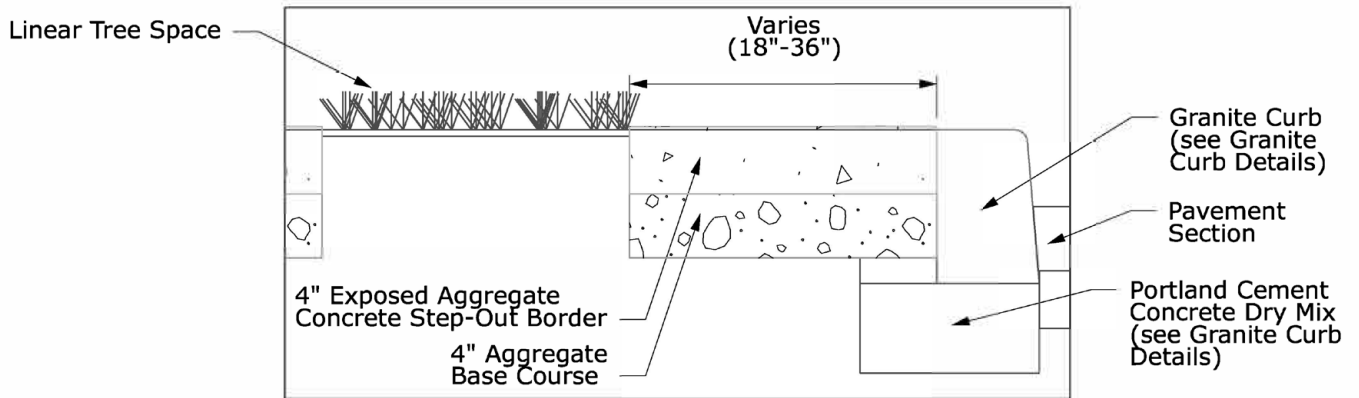

SECTION VIEW

EXPOSED AGGREGATE CONCRETE STEP-OUT CURB BORDER

No Scale

SIDEWALK SPECIFICATIONS – FOR EXPOSED AGGREGATE CONCRETE, STEP-OUT CURB BORDER, AND BUS STOP

DESCRIPTION

This work consists of constructing sidewalks, step-out curb borders, and bus stops.

MATERIAL

Supply materials conforming to the Monumental Core Construction Manual details for individual components, project plans, and specifications of the jurisdiction administering the project as approved by the Contracting Officer (CO).

For sidewalks, match the color and texture of the Eisenhower Memorial and Lock Keepers House sidewalk installations as directed by the CO.

As required, provide samples indicating the actual color, textures, finish, and workmanship to the CO for approval. Ensure that submitted samples are free of damage, chips, breaks, discoloration, stains, or other defects. Obtain CO approval prior to beginning construction.

CONSTRUCTION REQUIREMENTS

Construct individual components according to the construction requirements for that component as shown in the Monumental Core Construction Manual, current edition.

Protect materials against moisture, freezing, soiling, staining, and physical damage during storage and construction. Handle materials in a manner to prevent soiling, staining, and other damage.

During construction, erect a protective fence around the work area to keep vehicles and pedestrians out of the work area. Erect perimeter erosion controls as required by the CO, plans, and environmental permitting requirements. Maintain all erosion controls and replace failed controls throughout the duration of the work. Obtain CO approval of the completed work before removing fencing and erosion controls and demobilizing.

BUS PAD DETAIL

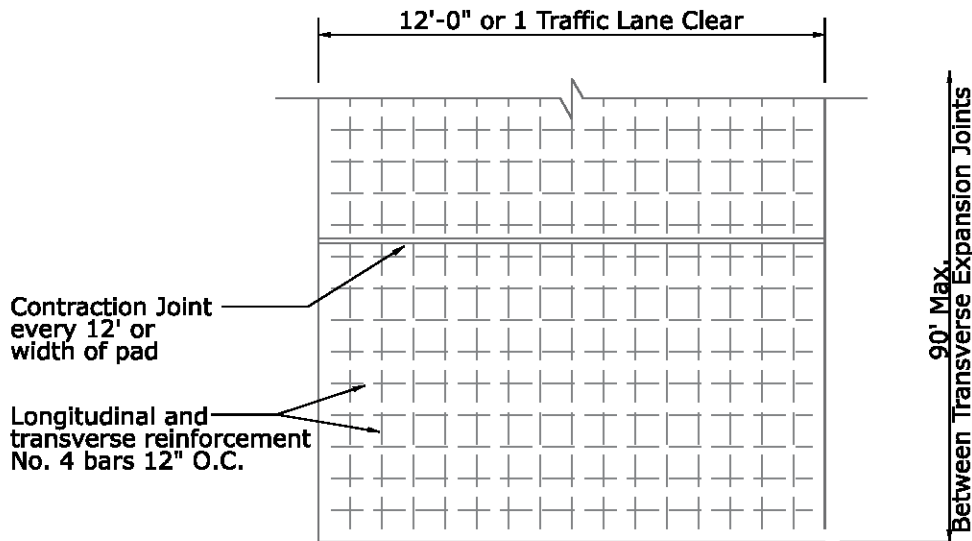

PLAN: BUS PAD

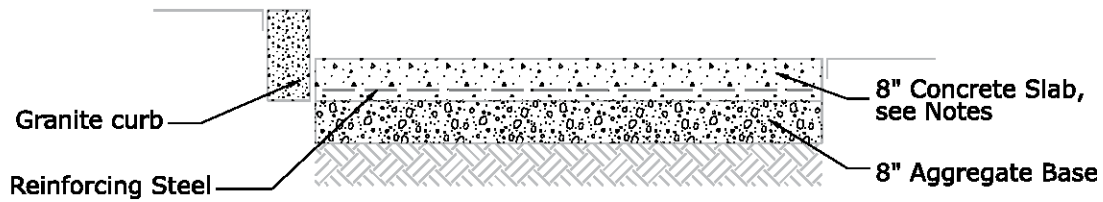

SECTION: BUS PAD

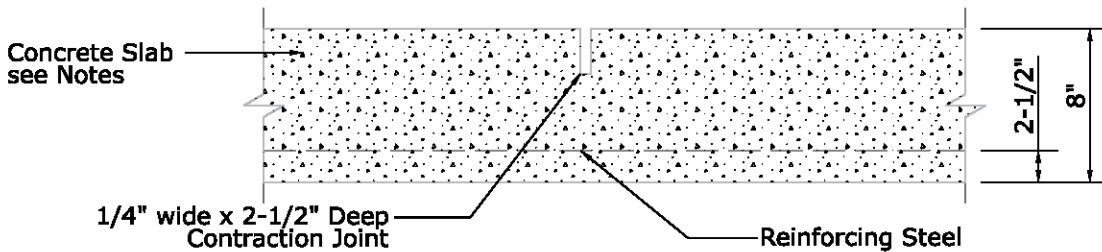

SECTION: CONTRACTION JOINT

NOTES

1. Thickness of slab may vary depending on subgrade conditions
2. Match concrete base joints
3. For projects located in areas maintained by the NPS, concrete slab will be blackened according to the design plans and at the direction of the COR.

No Scale

BUS PAD

BUS PAD SPECIFICATIONS

DESCRIPTION

This work consists of constructing a concrete bus pad.

MATERIAL

Supply materials conforming to the Monumental Core Construction Manual details for individual components, project plans, and specifications of the jurisdiction administering the project as approved by the Contracting Officer (CO).

As required, provide samples indicating the actual color, textures, finish, and workmanship to be executed in the final work. Ensure that submitted samples are free of damage, chips, breaks, discoloration, stains, or other defects. Obtain approval from the CO prior to beginning construction.

Supply workers skilled in the construction of individual components of the bus pad.

For projects under National Park Service jurisdiction, construct bus pad using blackened concrete. Submit a 4' x 4' x 5" test panel of tinted concrete for CO approval prior to beginning concrete work. Ensure that submitted sample panels are prepared using the same material and methods intended for use in the actual work and that test panels are free from damage or staining. Construct test panels separately from the bus pad and submit test panels early enough to allow time for approval before construction.

CONSTRUCTION REQUIREMENTS

Construct individual components according to the construction requirements for that component as shown in the Monumental Core Construction Manual, current edition, or the relevant DDOT or FHWA specification.

Protect materials against moisture, freezing, soiling, staining, and physical damage during storage and construction. Handle materials in a manner to prevent soiling, staining, and other damage.

During construction, erect a protective fence around the work area to keep vehicles and pedestrians out of the work area. Erect perimeter erosion controls as required by the CO, plans, and environmental permitting requirements. Maintain all erosion controls and replace failed controls throughout the duration of the work. Obtain CO approval of the completed work before removing fencing and erosion controls and demobilizing.

EXPOSED AGGREGATE WHEELCHAIR RAMP DETAIL

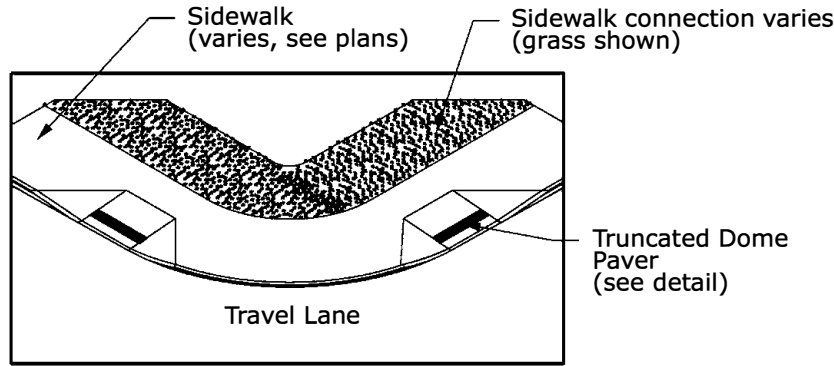

ISOMETRIC VIEW

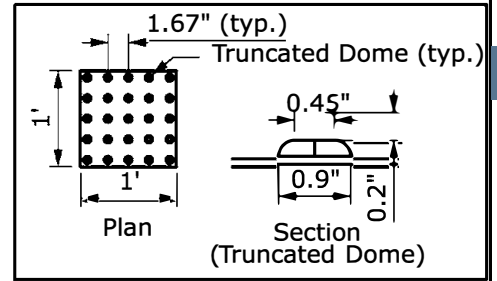

TRUNCATED DOME PAVER DETAIL

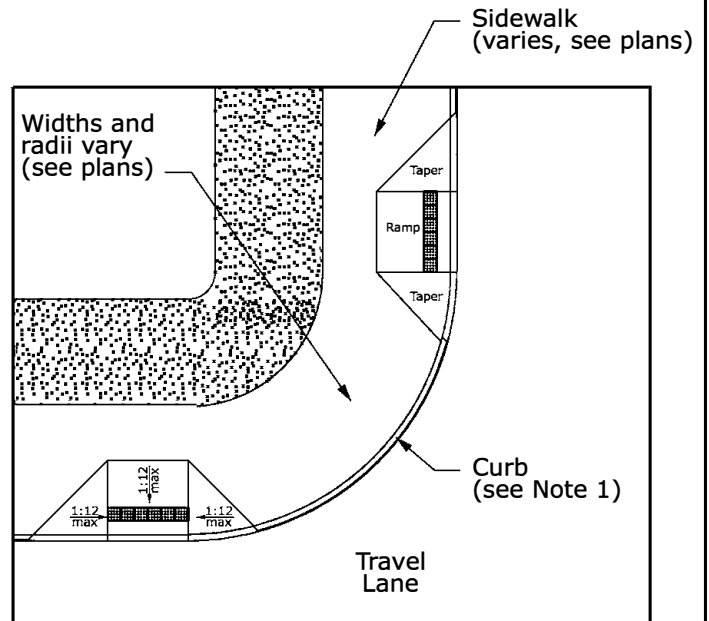
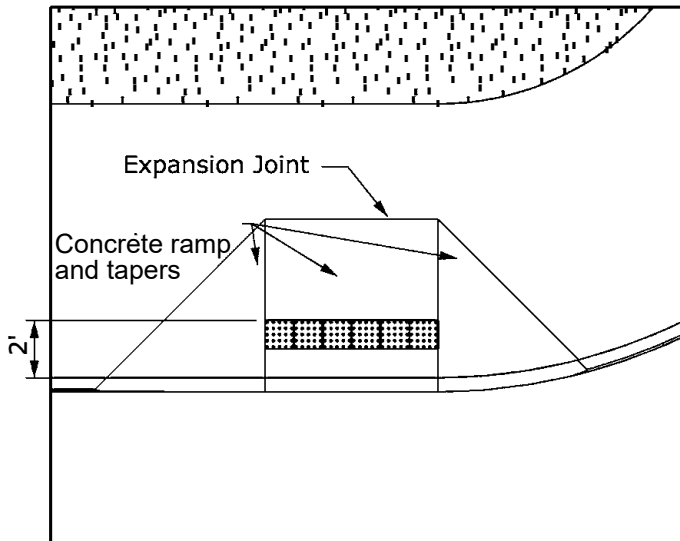

TOP VIEW

NOTES

1. Curb/gutter type may vary (granite curb with asphalt/no gutter shown). See design plans for specific configuration.
2. Depths/materials for sidewalk, travel lanes, and other features not shown for clarity. See asphalt, sidewalk, and/or curb details for design information for those elements.
3. Provide truncated domes with color hues complementing the color of adjacent sidewalk materials but with sufficient contrast to distinguish domes from surrounding ramp. Submit samples to the COR and obtain approval prior to installation.

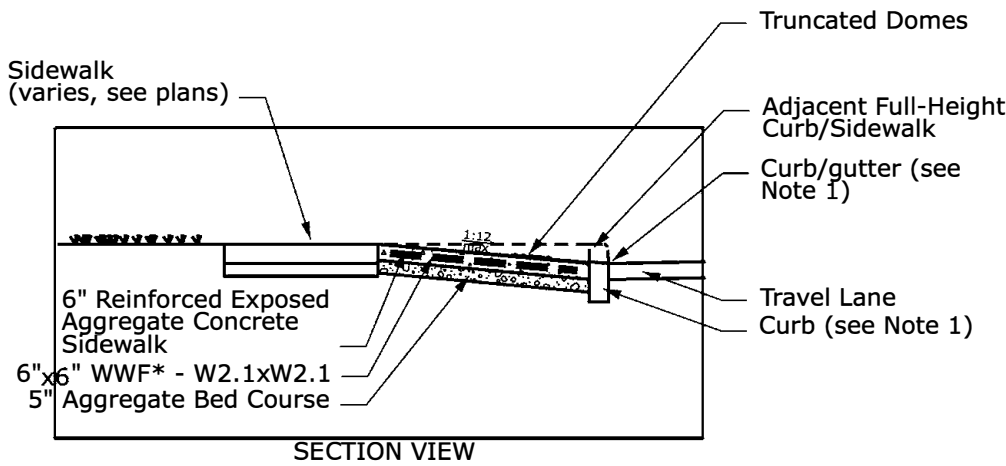

SECTION VIEW

*Welded Wire Fabric

No Scale

WHEELCHAIR RAMP DETAIL EXPOSED-AGGREGATE CONCRETE

GRANITE WHEELCHAIR RAMP DETAIL

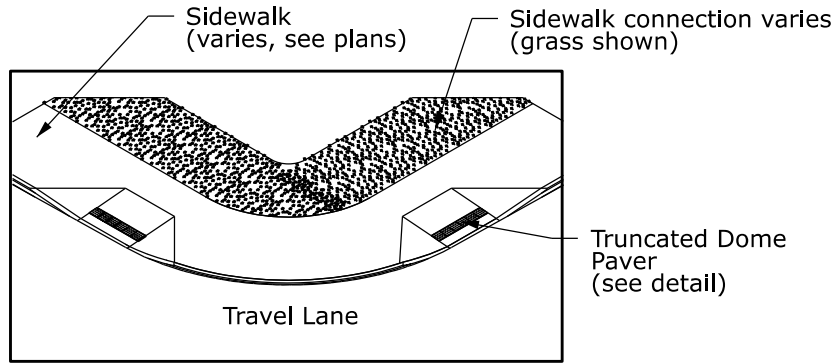

ISOMETRIC VIEW

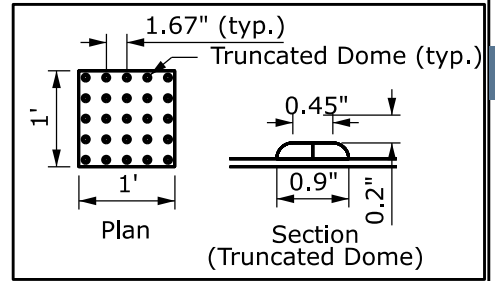

TRUNCATED DOME PAVER DETAIL

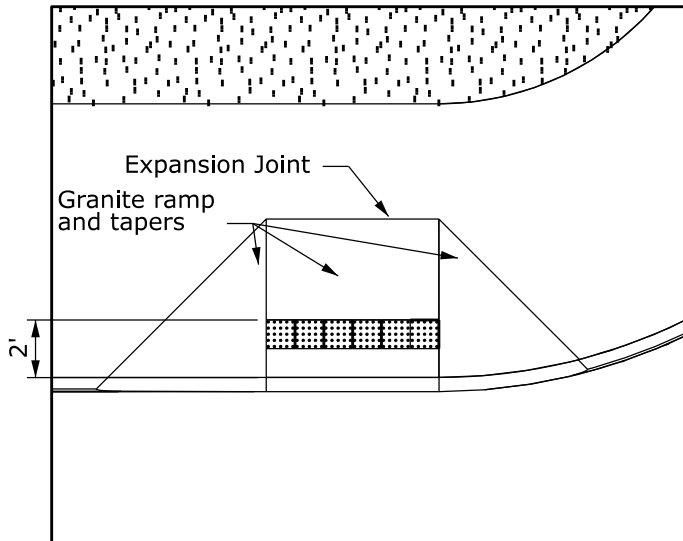

RAMP DETAIL PLAN VIEW

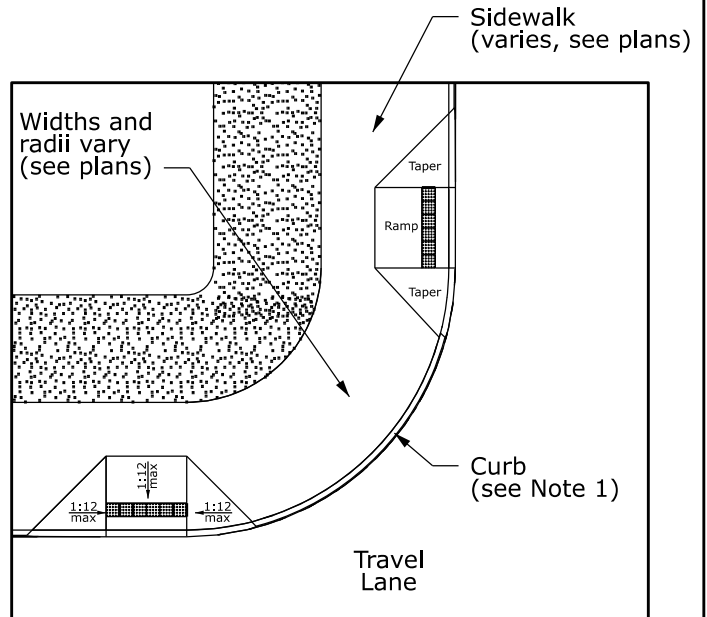

TOP VIEW

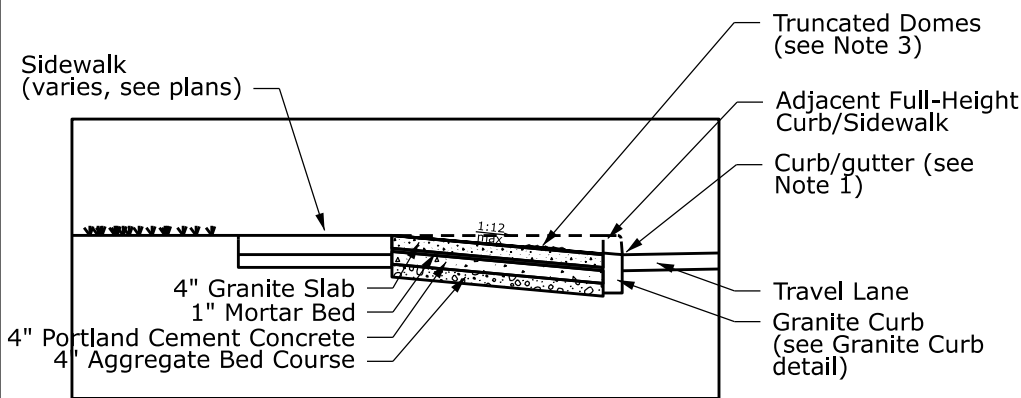

SECTION VIEW

NOTES

1. Curb/gutter type may vary (granite curb with asphalt/no gutter shown). See design plans for specific configuration.
2. Depths/materials for sidewalk, travel lanes, and other features not shown for clarity. See asphalt, sidewalk, and/or curb details for design information for those elements.
3. Provide truncated domes with color hues complementing the color of adjacent sidewalk materials but with sufficient contrast to distinguish domes from surrounding ramp. Submit samples to the COR and obtain approval prior to installation.

WHEELCHAIR RAMP DETAIL - GRANITE

No Scale

WHEELCHAIR RAMP SPECIFICATIONS – FOR EXPOSED AGGREGATE CONCRETE AND GRANITE RAMPS

DESCRIPTION

This work consists of accessible ramps.

MATERIAL

For exposed aggregate concrete ramps, refer to material requirements for Exposed Aggregate Concrete Sidewalks.

For granite ramps, refer to material requirements for Granite Curb.

Provide truncated domes with color hues complementing the color of adjacent sidewalk materials but with sufficient contrast to distinguish domes from surrounding ramp.

For all other components, supply materials conforming to the Monumental Core Construction Manual details for individual components, project plans, and specifications of the jurisdiction administering the project as approved by the Contracting Officer (CO).

Supply workers skilled in the construction and/or placement of individual items.

Submit material samples as required to the CO and obtain approval prior to installation. Ensure that submitted samples are free of damage, chips, breaks, discoloration, stains, or other defects.

CONSTRUCTION REQUIREMENTS

Construct exposed aggregate concrete ramps according to Exposed Aggregate Concrete Sidewalk specifications, Monumental Core Construction Manual, current edition.

Construct granite ramps according to Granite Curb specifications, Monumental Core Construction Manual, current edition.

Protect materials against moisture, freezing, soiling, staining, and physical damage during storage and construction. Handle materials in a manner to prevent soiling, staining, and other damage.

During construction, erect a protective fence around the work area to keep vehicles and pedestrians out of the work area. Erect perimeter erosion controls as required by the CO, plans, and environmental permitting requirements. Maintain all erosion controls and replace failed controls throughout the duration of the work. Obtain CO approval of the completed work before removing fencing and erosion controls and demobilizing.

POROUS ASPHALT PAVEMENT DETAIL

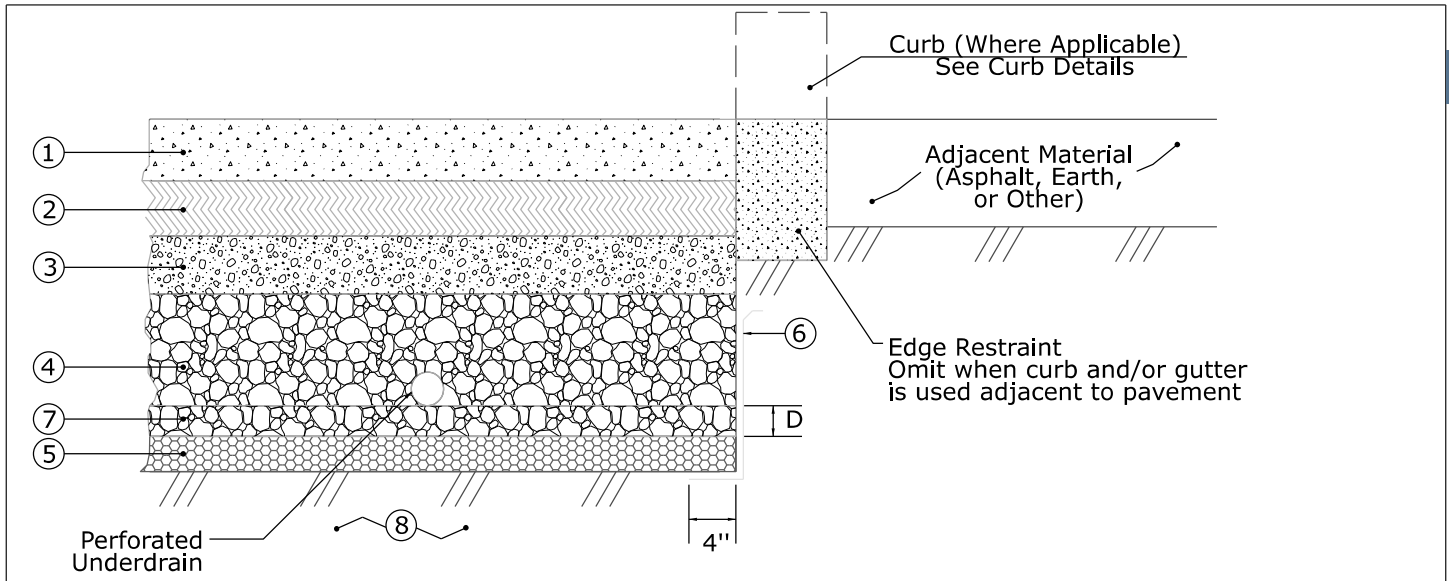

ROAD / ALLEY SECTION

LEGEND

- 1 Porous Asphalt Surface Course - HMA 12.5mm
- 2 Porous Asphalt Base Course - HMA 22mm
- 3 Choker Layer, AASHTO #57 or Approved Equal
- 4 Reservoir Layer, AASHTO #3, #2, or #57, or Approved Equal*
* AASHTO #57 to be used only with Maximum Reservoir Depth of 8'
- 5 Filter Layer (See Note 7), AASHTO #8 or Approved Equal
- 6 Geotextile Class 2, located on sides of practices only
- 7 Infiltration Sump - for standard design, D = 0"
For enhanced design, See Note 6
- 8 Uncompacted Subgrade for areas designed for infiltration practices.
For other areas, compact as specified in specification cited in Note 2.
For soft soils, install geogrid per Geotechnical Engineer Recommendations.

NOTES

- 1. Depending on location/jurisdiction of the site, conform to current approved DDOT or FHWA specification for porous asphalt pavement.
- 2. Aggregate layers shall meet current approved specification for Aggregates for Permeable Pavement and Bioretention.
- 3. See design plans for longitudinal and cross slope requirements
- 4. Waterproof membrane to be used to promote water re-use, protect nearby building foundations, and avoid infiltration around utilities. See design plans.
- 5. Depth of reservoir layer as shown on design plans should be sized to address stormwater management and conveyance requirements, and pavement structural design.
- 6. Enhanced design contains a water storage layer and an infiltration sump beneath the underdrain sized to drain the design storm within 48 hours.
- 7. When filter layer is omitted, provide geotextile class 1 material beneath reservoir layer meeting current approved DDOT specification for 'geosynthetics for stormwater facilities'.
- 8. Bottom of permeable pavement structure shall be at least 2' above the seasonal high water table or bedrock, as determined by geotechnical investigation.
- 9. Top of pavement should be designed to achieve 1% minimum slope in any direction.

MINIMUM PAVEMENT THICKNESS

PAVEMENT ITEM	CLASS A	CLASS B
1	1.5"	3"
2	3"	6"
3	4"	4"
4	6", See Note 5	12", See Note 5
5	4"	4"

Class A: Alley, Parking Lane, Local Street
Class B: Collector or Arterial (not currently allowed)

POROUS PAVEMENT

No Scale

*Detail adapted from DDOT DWG. No. 621.03

POROUS ASPHALT PAVEMENT SPECIFICATIONS

DESCRIPTION

This work consists of constructing a porous asphalt pavement section.

MATERIAL

Supply materials conforming to the Monumental Core Construction Manual details for individual components, project plans, and specifications of the jurisdiction administering the project as approved by the Contracting Officer (CO).

Supply workers skilled in the construction and/or placement of individual items.

As required, provide samples indicating the actual color, textures, finish, and workmanship to be executed in the final work. Ensure that submitted samples are free of damage, chips, breaks, discoloration, stains, or other defects. Obtain approval from the CO prior to beginning construction.

CONSTRUCTION REQUIREMENTS

Construct individual components according to the construction requirements for that component as shown in the Monumental Core Construction Manual, current edition, or the relevant DDOT or FHWA specification.

Protect materials against moisture, freezing, soiling, staining, and physical damage during storage and construction. Handle materials in a manner to prevent soiling, staining, and other damage.

During construction, erect a protective fence around the work area to keep vehicles and pedestrians out of the work area. Erect perimeter erosion controls as required by the CO, plans, and environmental permitting requirements. Maintain all erosion controls and replace failed controls throughout the duration of the work. Obtain CO approval of the completed work before removing fencing and erosion controls and demobilizing.

DRIVEWAY APRON DETAIL

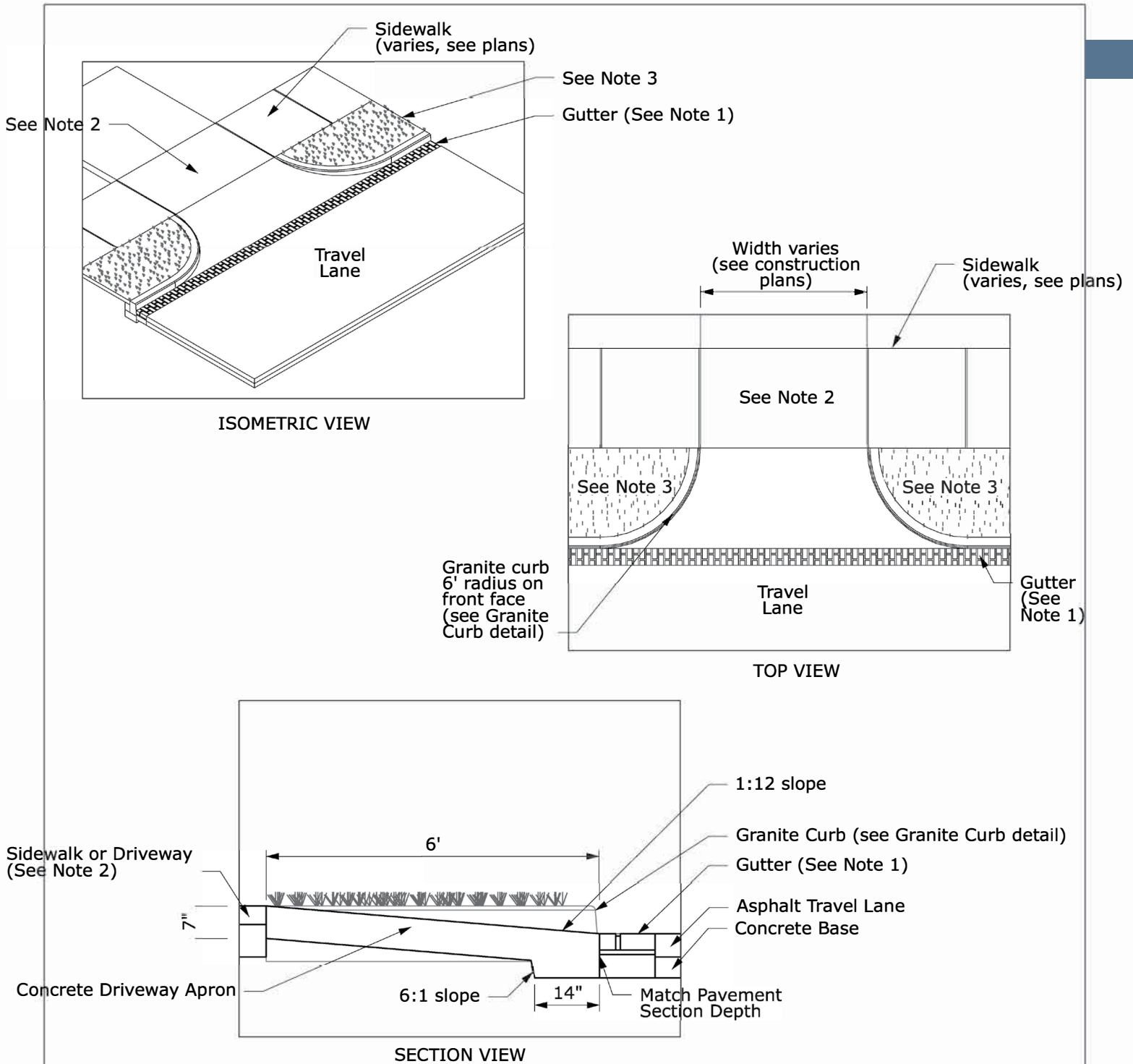

NOTES

1. Gutter may be brick or asphalt (brick shown). See brick/asphalt gutter details.
2. Where constructed driveway crosses sidewalk, construct base to match driveway and construct surface to match sidewalk as a visual cue that vehicles yield to pedestrians.
3. Buffer may be grass or other landscaping (grass shown). See construction plans.

No Scale

DRIVEWAY APRON

DRIVEWAY APRON SPECIFICATIONS

DESCRIPTION

This work consists of constructing driveway aprons including gutter, curb, sidewalk, and pavement.

MATERIAL

Supply materials conforming to the Monumental Core Construction Manual details for individual components, project plans, and specifications of the jurisdiction administering the project as approved by the Contracting Officer (CO). Depending on the location, supply red brick, yellow brick, or asphalt gutter as shown in the plans and as directed by the CO.

Supply workers skilled in the construction of individual components.

As required, provide samples indicating the actual color, textures, finish, and workmanship to be executed in the final work. Ensure that submitted samples are free of damage, chips, breaks, discoloration, stains, or other defects. Obtain approval from the CO prior to beginning construction.

CONSTRUCTION REQUIREMENTS

Construct individual components according to the construction requirements for that component as shown in the Monumental Core Construction Manual, current edition, or the relevant DDOT or FHWA specification.

Protect materials against moisture, freezing, soiling, staining, and physical damage during storage and construction. Handle materials in a manner to prevent soiling, staining, and other damage.

During construction, erect a protective fence around the work area to keep vehicles and pedestrians out of the work area. Erect perimeter erosion controls as required by the CO, plans, and environmental permitting requirements. Maintain all erosion controls and replace failed controls throughout the duration of the work. Obtain CO approval of the completed work before removing fencing and erosion controls and demobilizing.

CONCRETE MEDIAN DETAIL

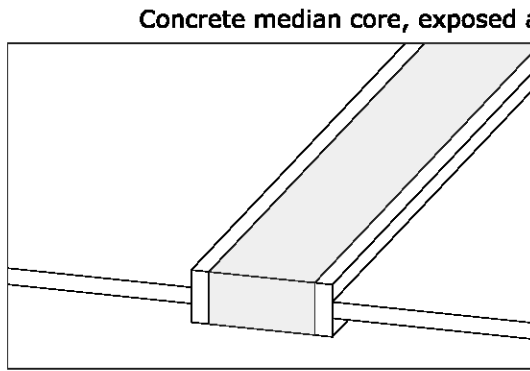

ISOMETRIC VIEW

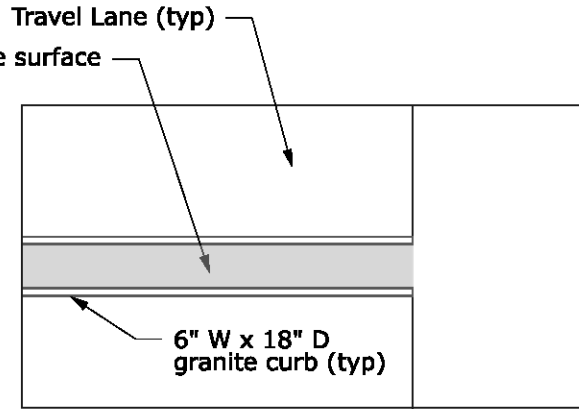

PLAN VIEW

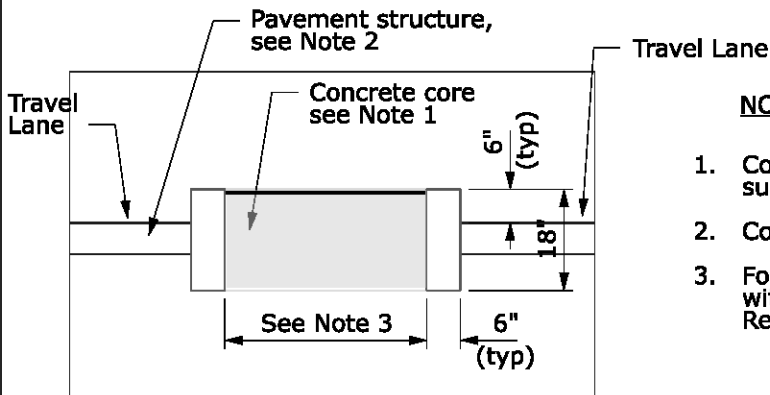

SECTION VIEW

NOTES

1. Construct concrete core with an exposed aggregate surface (not shown)
2. Construct pavement according to asphalt specifications
3. For DDOT routes, minimum core width is 3' (4' total with curb). For NPS routes, minimum width varies. Refer to the plans for specific median dimensions.

CONCRETE MEDIAN SPECIFICATIONS

DESCRIPTION

This work consists of constructing a median with exposed aggregate concrete core and granite curb.

MATERIAL

For exposed aggregate concrete, conform to the Sidewalk - Exposed Aggregate Concrete section of the Monumental Core Construction Manual, current edition.

For granite curb, conform to the Granite Curb section of the Monumental Core Construction Manual, current edition.

For all other items, supply materials conforming to the Monumental Core Construction Manual details for individual components, project plans, and specifications of the jurisdiction administering the project as approved by the Contracting Officer (CO).

Supply workers skilled in the construction and/or placement of individual items.

As required, provide samples indicating the actual color, textures, finish, and workmanship to be executed in the final work. Ensure that submitted samples are free of damage, chips, breaks, discoloration, stains, or other defects. Obtain approval from the CO prior to beginning construction.

CONSTRUCTION REQUIREMENTS

Construct individual components according to the construction requirements for that component as shown in the Monumental Core Construction Manual, current edition, or the relevant DDOT or FHWA specification.

Protect materials against moisture, freezing, soiling, staining, and physical damage during storage and construction. Handle materials in a manner to prevent soiling, staining, and other damage.

During construction, erect a protective fence around the work area to keep vehicles and pedestrians out of the work area. Erect perimeter erosion controls as required by the CO, plans, and environmental permitting requirements. Maintain all erosion controls and replace failed controls throughout the duration of the work. Obtain CO approval of the completed work before removing fencing and erosion controls and demobilizing.

SEPARATED BIKE LANE DETAIL

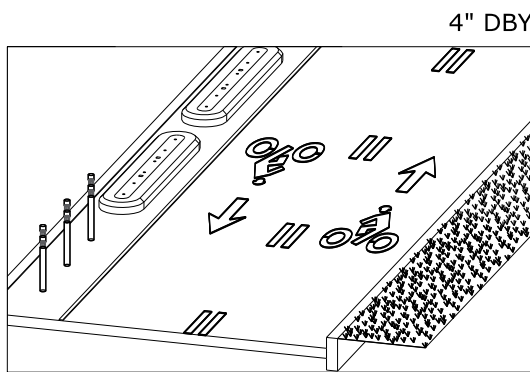

ISOMETRIC VIEW

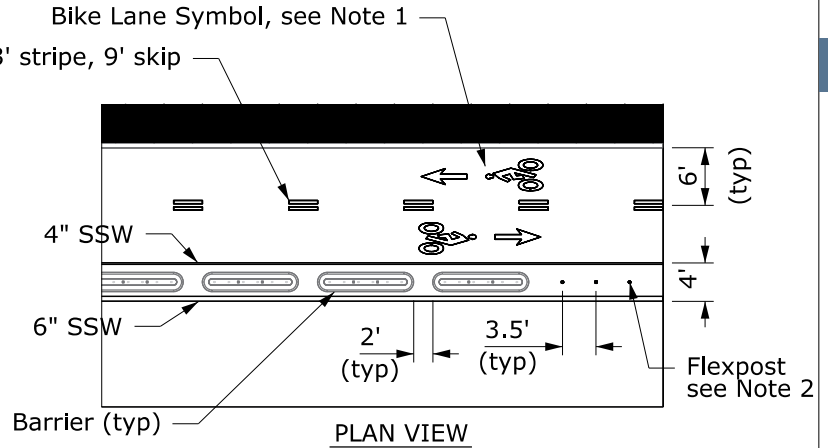

KEY

DBY - Double Broken Yellow
 SSW - Single Solid White

NOTES

1. Place bike lane symbols 250' apart or as shown in the plans
2. Place 3 flexposts at approaches to intersections
3. Cycle Lane and Buffer widths may vary; refer to plans for actual dimensions
4. Curb and grass shown; actual conditions may vary by site
5. See asphalt specifications for pavement structure
6. Construct a 3/4" chamfer on all bottom edges of barrier and construct a 1" fillet on all top edges (not shown)

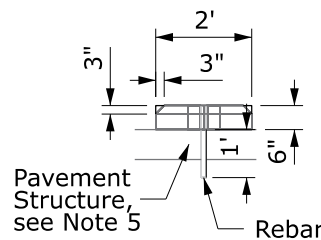
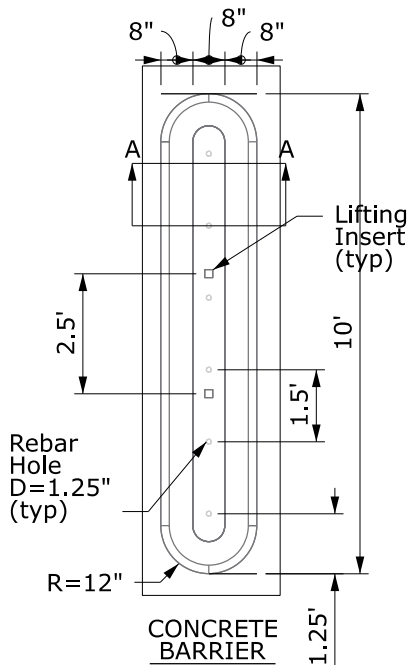
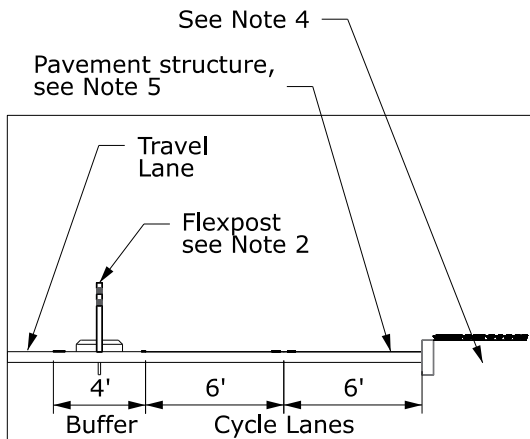

SECTION A-A

SEPARATED BICYCLE LANE WITH CONCRETE BARRIER

No Scale

SEPARATED BICYCLE LANE SPECIFICATIONS – CONCRETE BARRIER

DESCRIPTION

This work consists of constructing a two-way bicycle lane, separated from traffic, with asphalt pavement, removable concrete barriers, pavement markings, and flexposts.

MATERIAL

Supply materials conforming to the Monumental Core Construction Manual details for individual components, project plans, and specifications of the jurisdiction administering the project as approved by the Contracting Officer (CO).

Supply workers skilled in the construction and/or placement of individual items.

As required, provide samples indicating the actual color, textures, finish, and workmanship to be executed in the final work. Ensure that submitted samples are free of damage, chips, breaks, discoloration, stains, or other defects. Obtain approval from the CO prior to beginning construction.

CONSTRUCTION REQUIREMENTS

Construct individual components according to the construction requirements for that component as shown in the Monumental Core Construction Manual, current edition, or the relevant DDOT or FHWA specification.

Protect materials against moisture, freezing, soiling, staining, and physical damage during storage and construction. Handle materials in a manner to prevent soiling, staining, and other damage.

During construction, erect a protective fence around the work area to keep vehicles and pedestrians out of the work area. Erect perimeter erosion controls as required by the CO, plans, and environmental permitting requirements. Maintain all erosion controls and replace failed controls throughout the duration of the work. Obtain CO approval of the completed work before removing fencing and erosion controls and demobilizing.

Curbs and Gutters

GRANITE CURB (DC) DETAIL

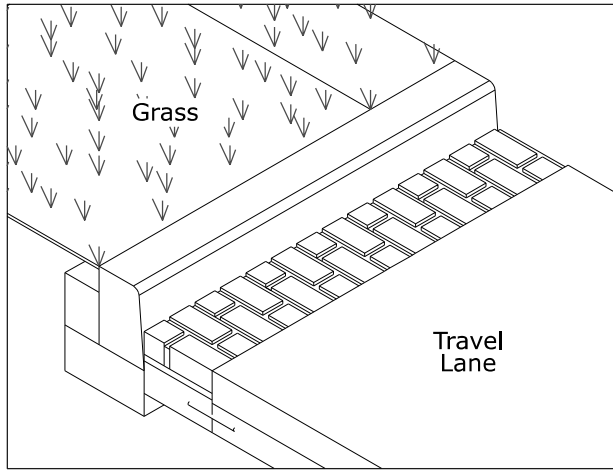

ISOMETRIC VIEW

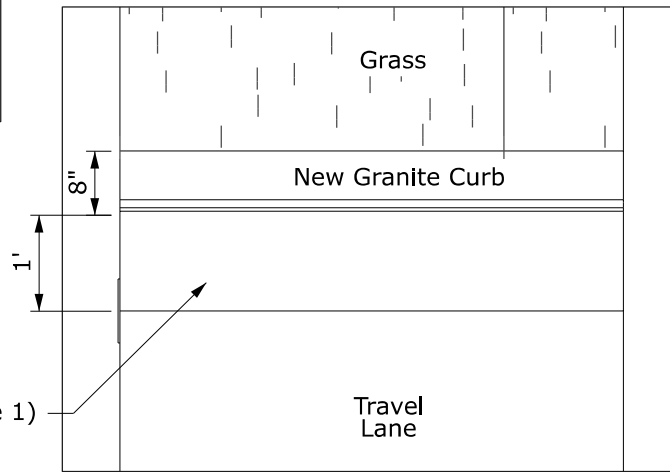

TOP VIEW

Backfill with Portland Cement Concrete, Cover with 4" soil or sidewalk (soil shown)

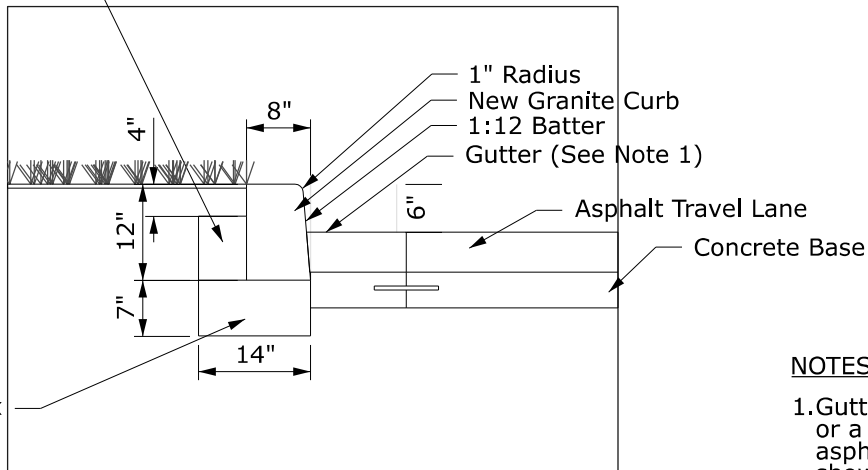

SECTION VIEW

NOTES

1. Gutter may be brick or a continuation of the asphalt pavement (brick shown in Isometric View, Asphalt shown in Top/Section Views). Match travel lane section for asphalt; see brick gutter details for brick gutter dimensions.

No Scale

D.C. GRANITE CURB

GRANITE CURB (NPS) DETAIL

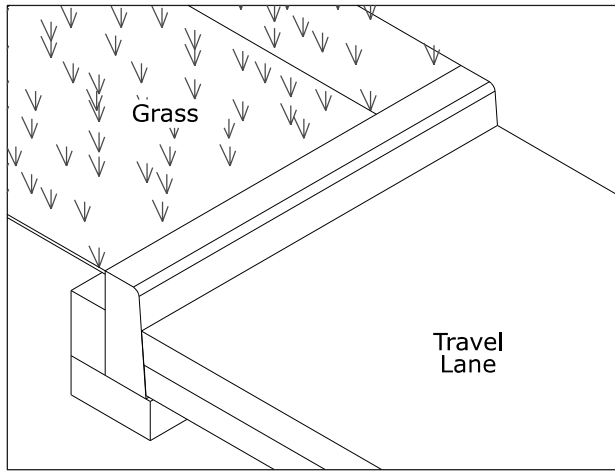

ISOMETRIC VIEW

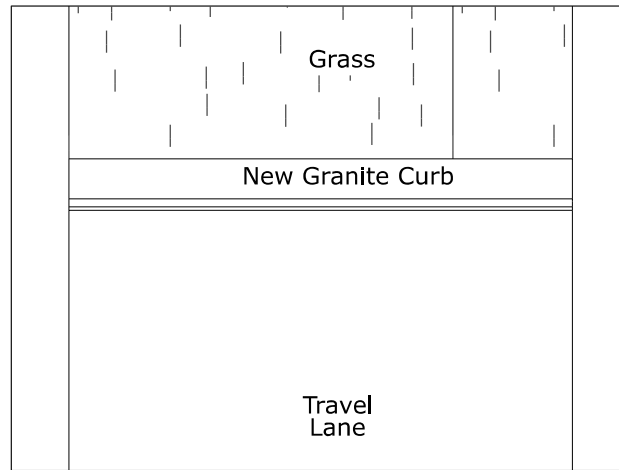

TOP VIEW

Backfill with Portland Cement Concrete, Cover with 6" soil or sidewalk section (soil shown)

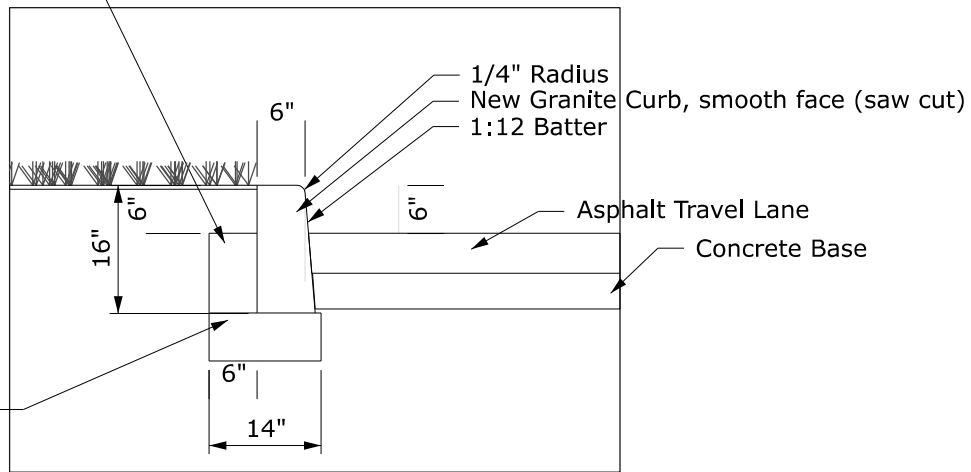

SECTION VIEW

NPS GRANITE CURB

No Scale

GRANITE CURB SPECIFICATIONS

DESCRIPTION

This work consists of constructing granite curb.

MATERIAL

Supply granite, base, and backfill material conforming to DDOT specifications, latest edition.

For National Park Service projects, supply Virginia Mist or Fox Hill granite, or approved equal.

Supply workers skilled in the construction and/or placement of individual items.

As required, provide samples indicating the actual color, textures, finish, and workmanship to be executed in the final work. Ensure that submitted samples are free of damage, chips, breaks, discoloration, stains, or other defects. Obtain approval from the Contracting Officer (CO) prior to beginning construction.

CONSTRUCTION REQUIREMENTS

Construct individual components according to the construction requirements for that component as shown in the Monumental Core Construction Manual, current edition, or the relevant DDOT or FHWA specification.

Protect materials against moisture, freezing, soiling, staining, and physical damage during storage and construction. Handle materials in a manner to prevent soiling, staining, and other damage.

Construct Portland cement base and backfill according to DDOT specifications, latest edition. Construct all other components according to the construction requirements for that component as shown in the Monumental Core Construction Manual, current edition, or the relevant DDOT or FHWA specification.

If adjacent material is grass or other landscaping, place 4" topsoil on top of the backfill. If adjacent material is concrete, brick, or other sidewalk material, construct the adjacent material on top of the Portland cement backfill material and flush with the back and top of the curb.

During construction, erect a protective fence around the work area to keep vehicles and pedestrians out of the work area. Erect perimeter erosion controls as required by the CO, plans, and environmental permitting requirements. Maintain all erosion controls and replace failed controls throughout the duration of the work. Obtain CO approval of the completed work before removing fencing and erosion controls and demobilizing.

BLUESTONE CURB SPECIFICATIONS

DESCRIPTION

This work consists of maintenance of Bluestone curb.

MAINTENANCE REQUIREMENTS

Maintain Bluestone curb according to the Bluestone Curbing section of the DDOT Design and Engineering Manual, latest edition.

CURB INLET AND GUTTER DETAIL

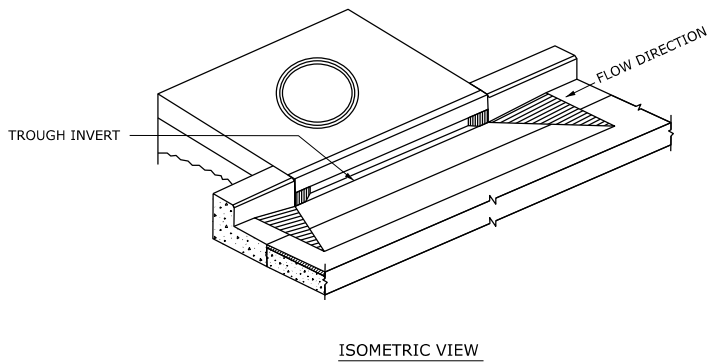
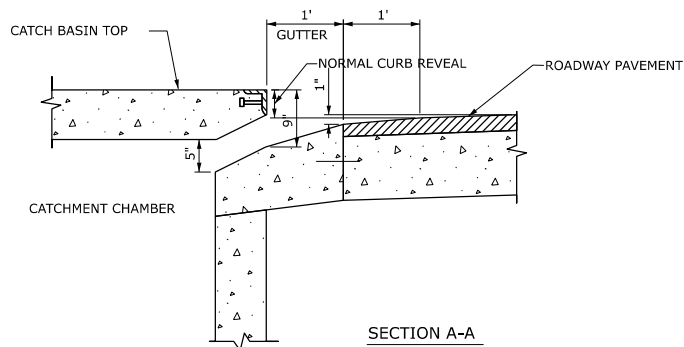
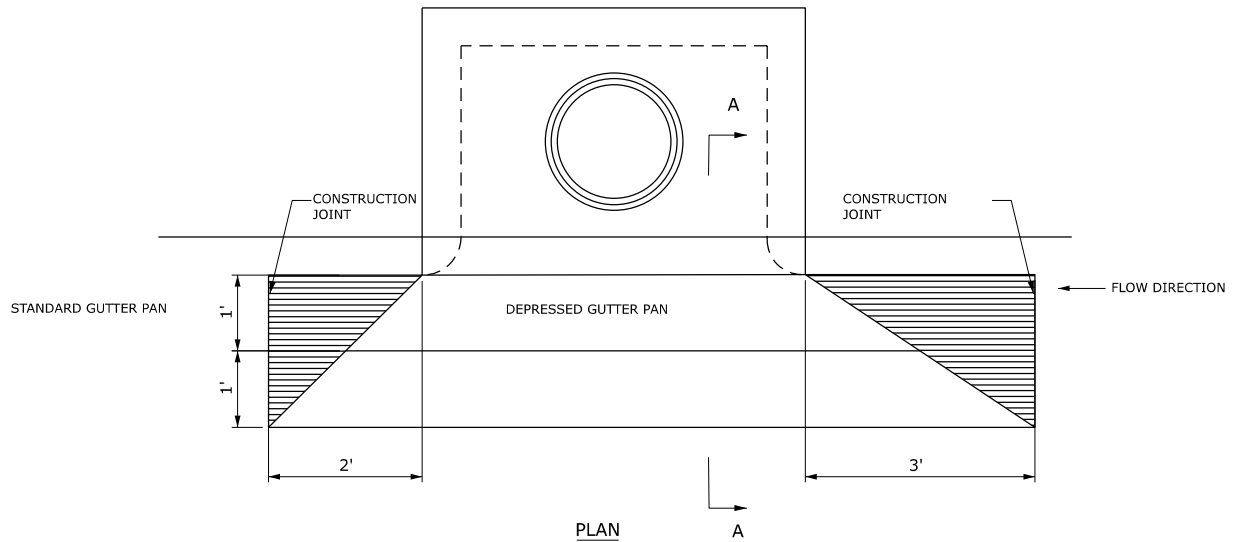

Notes:

1. Catch basin and catchment chamber dimensions will vary based on site conditions and individual project requirements.
2. See curb/gutter details and specifications for curb/gutter materials and dimensions.

No Scale

**CURB INLET WITH
DEPRESSED GUTTER**
*Detail adapted from DDOT DWG. No. 310.04

CURB INLET AND GUTTER SPECIFICATIONS

DESCRIPTION

This work consists of constructing curb inlets for catch basins with depressed/sloped gutter pans.

MATERIAL

Construct catch basin top to match surrounding sidewalk. Refer to material requirements for adjacent sidewalks.

Construct gutter to match surrounding gutter. Refer to material requirements for adjacent gutter.

Submit samples for all materials to the Contracting Officer (CO) for approval prior to construction/installation.

CONSTRUCTION REQUIREMENTS

Construct adjacent catch basin/catchment according to design plans and site requirements. Adjust dimensions of curb inlet, catch basin top, and gutter as needed to match catch basin dimensions and fit field conditions.



ASPHALT GUTTER DETAIL

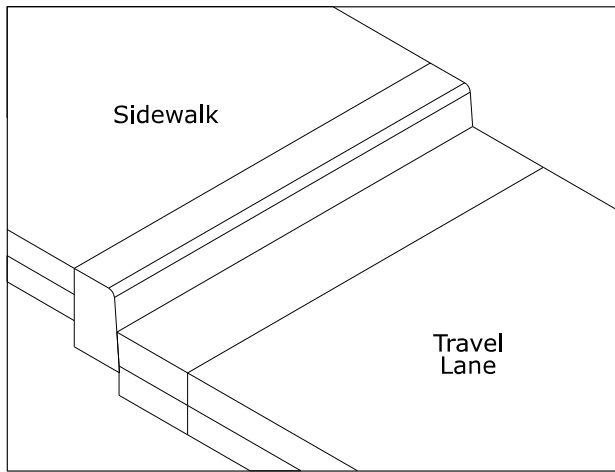

ISOMETRIC VIEW

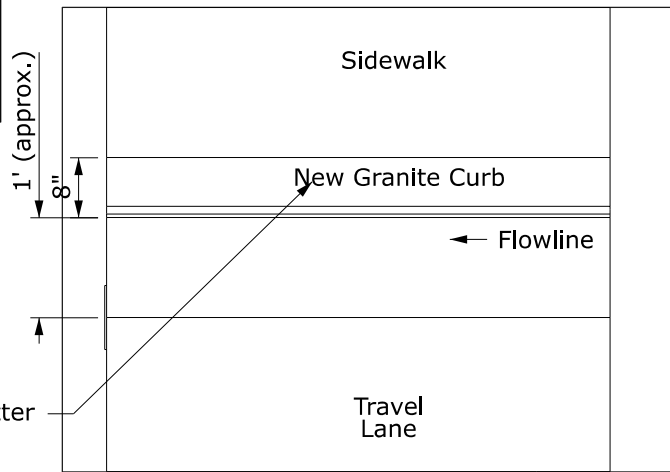

TOP VIEW

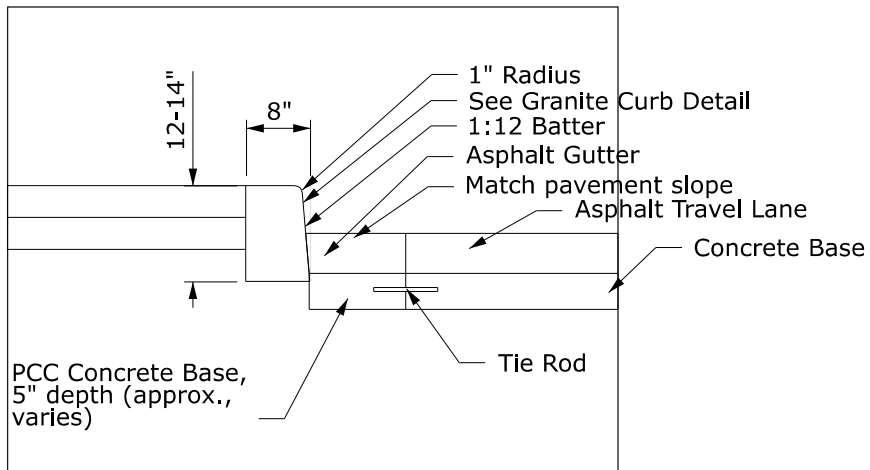

SECTION VIEW

No Scale

ASPHALT GUTTER

ASPHALT GUTTER SPECIFICATIONS

DESCRIPTION

This work consists of constructing asphalt gutter.

MATERIAL

Supply asphalt and Portland cement base material conforming to DDOT specifications, current edition, as approved by the Contracting Officer (CO).

For all other work items, supply materials conforming to the Monumental Core Construction Manual details for individual components, project plans, and specifications of the jurisdiction administering the project as approved by the CO.

Supply workers skilled in the construction and/or placement of individual items.

As required, provide samples indicating the actual color, textures, finish, and workmanship to be executed in the final work. Ensure that submitted samples are free of damage, chips, breaks, discoloration, stains, or other defects. Obtain approval from the CO prior to beginning construction.

CONSTRUCTION REQUIREMENTS

Construct individual components according to the construction requirements for that component as shown in the Monumental Core Construction Manual, current edition, or the relevant DDOT or FHWA specification.

Protect materials against moisture, freezing, soiling, staining, and physical damage during storage and construction. Handle materials in a manner to prevent soiling, staining, and other damage.

During construction, erect a protective fence around the work area to keep vehicles and pedestrians out of the work area. Erect perimeter erosion controls as required by the CO, plans, and environmental permitting requirements. Maintain all erosion controls and replace failed controls throughout the duration of the work. Obtain CO approval of the completed work before removing fencing and erosion controls and demobilizing.

Construct Portland cement base to achieve 8.0% slope toward the curb as shown in the Asphalt Gutter detail.

BRICK GUTTER DETAIL

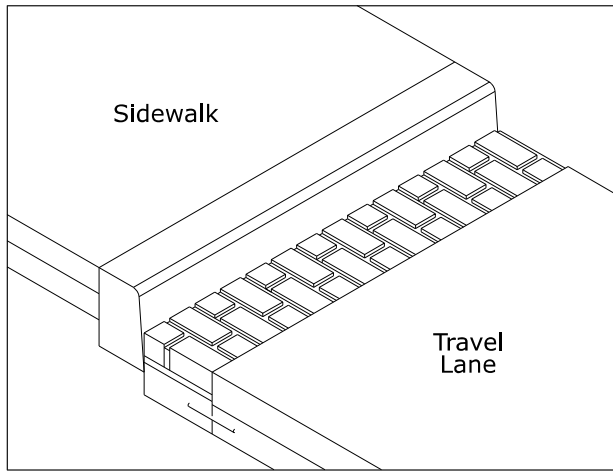

ISOMETRIC VIEW

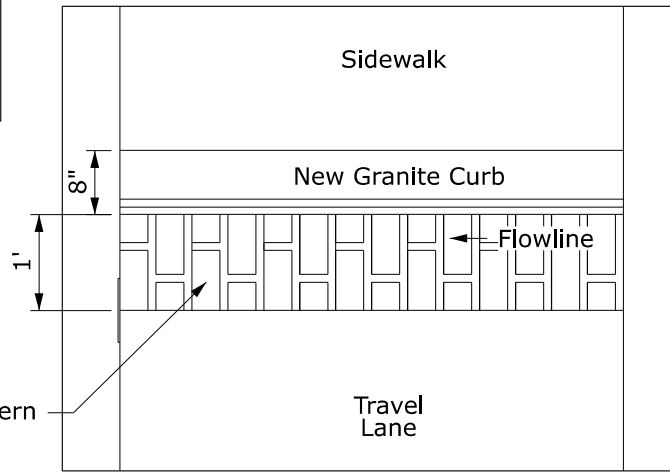

TOP VIEW

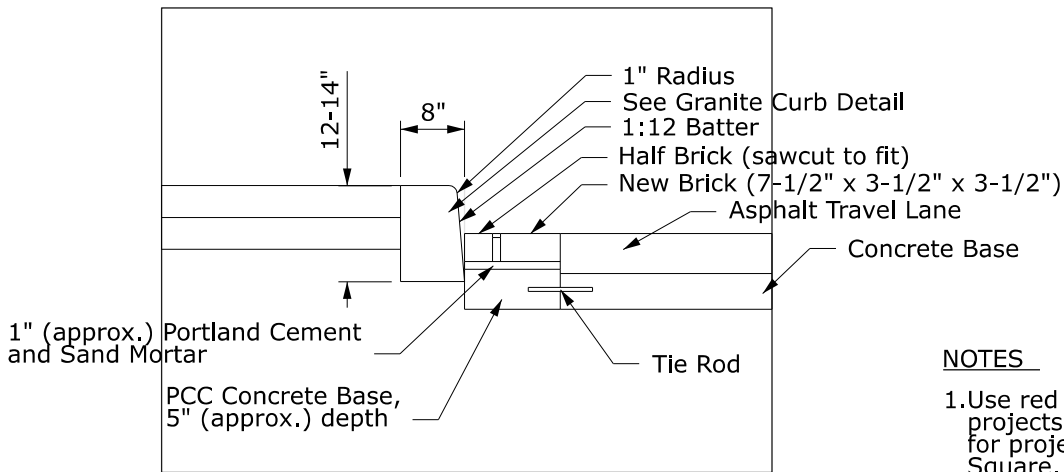

SECTION VIEW

NOTES

1. Use red brick for most DC projects, use yellow brick for projects near Capitol Square. Refer to the plans for locations and types used.

No Scale

BRICK GUTTER

BRICK GUTTER SPECIFICATIONS

DESCRIPTION

This work consists of constructing yellow or red brick gutter.

MATERIAL

Supply red brick material for most DC projects; supply yellow brick for projects near Capitol Square. Refer to the plans and determine the jurisdiction and brick type as directed by the Contracting Officer (CO). Reference the Monumental Core Streetscape Guide for jurisdiction information. Supply concrete base material and mortar material conforming to DDOT specifications, current edition.

For yellow brick gutter, supply brick from Louisville Fire Brick Works, Inc.

Supply workers skilled in the construction of brick gutter.

As required, provide samples indicating the actual color, textures, finish, and workmanship to be executed in the final work. Ensure that submitted samples are free of damage, chips, breaks, discoloration, stains, or other defects. Obtain approval from the CO prior to beginning construction.

CONSTRUCTION REQUIREMENTS

Construct individual components according to the construction requirements for that component as shown in the Monumental Core Construction Manual, current edition, or the relevant DDOT or FHWA specification.

Protect materials against moisture, freezing, soiling, staining, and physical damage during storage and construction. Handle materials in a manner to prevent soiling, staining, and other damage.

Place brick in a running bond pattern as shown in the Brick Gutter detail. Construct Portland cement and sand mortar with a 1" gap between bricks. Sawcut bricks to fit the pattern shown.

During construction, erect a protective fence around the work area to keep vehicles and pedestrians out of the work area. Erect perimeter erosion controls as required by the CO, plans, and environmental permitting requirements. Maintain all erosion controls and replace failed controls throughout the duration of the work. Obtain CO approval of the completed work before removing fencing and erosion controls and demobilizing.

Plantings, Soils, and Bioretention

TREE PLANTING DETAIL

NOTES

1. Test soil for percolation before construction to determine if underdrain is required. If required, install underdrain as directed by the CO.
2. Space trees at 50' on-center or as shown in the plans. Adjust spacing to meet site conditions as directed by the CO.
3. See detail U-1, sheet 2 of 2 for more information.
4. Do not pierce root ball with stakes.
5. Select soil continuous to roots of adjoining existing trees and to fill available planting area between curb and sidewalk.
6. Set flare of trunk 2-6" above finished grade and on undisturbed soil.

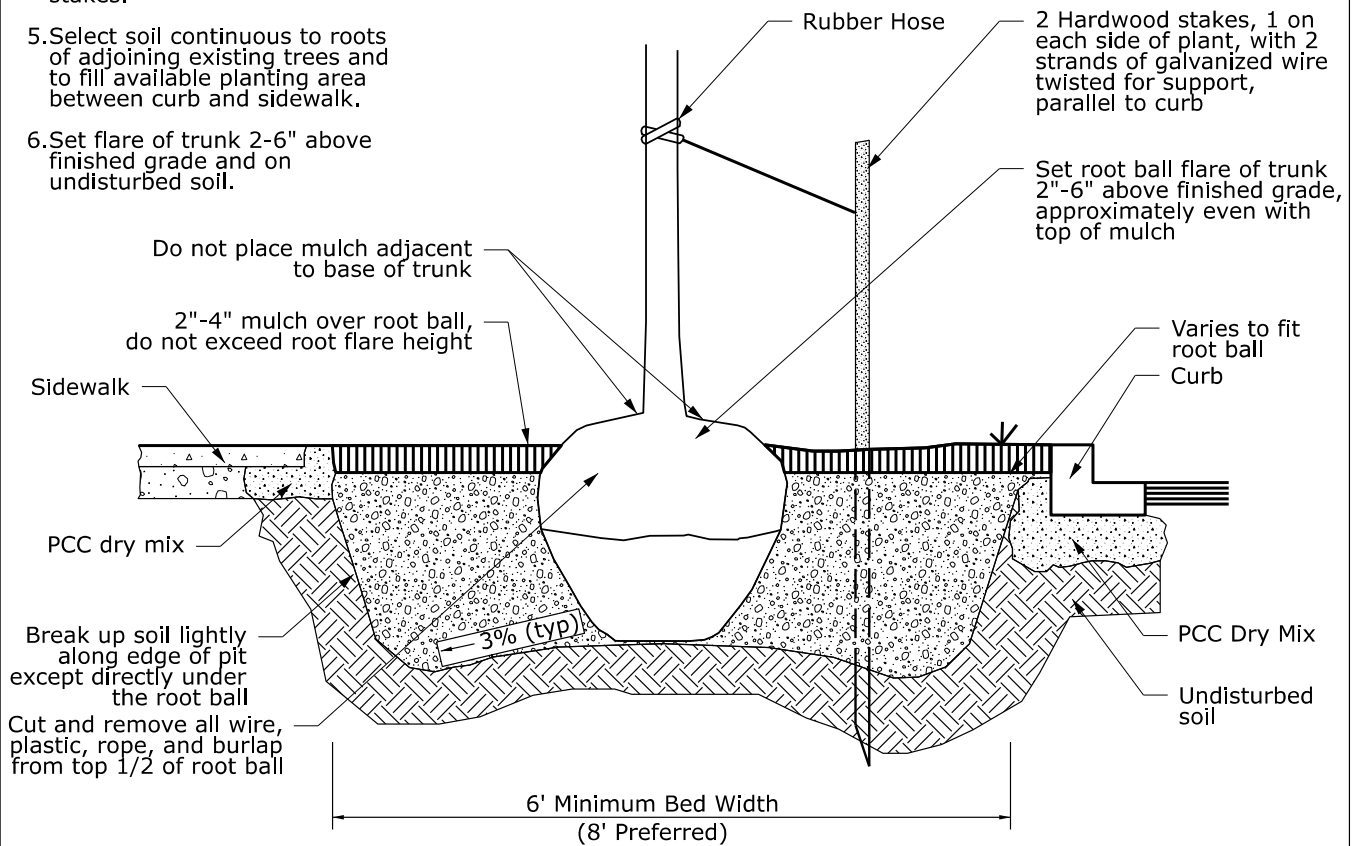

No Scale

INDIVIDUAL TREE REPLACEMENT

TREE PLANTING SPECIFICATIONS

DESCRIPTION

This work consists of furnishing and planting trees.

MATERIAL

Topsoil

Furnish fertile, friable, free draining, sandy loam soil that is free of subsoil, refuse, stumps, roots, brush, weeds, rocks larger than 1 inch (25 millimeters), or other substances detrimental to the development of vegetative growth. Demonstrate that the soil can sustain healthy crops of grass, shrubs, or other plant growth. Conform to the following:

(1) Texture

(a) Organic matter, AASHTO T 267	3.0 to 10.0 percent
(b) Sand, AASHTO T 88	20 to 70 percent
(c) Silt, AASHTO T 88	10 to 60 percent
(d) Clay, AASHTO T 88	5 to 30 percent

(2) pH, AASHTO T 289

5.5 to 8.0*

*required pH may vary by plant species.

Consult supplier guidelines.

Plant Material

Conform to the *American Standard for Nursery Stock*.

Furnish plants that are excellent representatives of their normal species or varieties. Furnish nursery grown stock that has been transplanted or root-trimmed two or more times according to the kind and size of plant. Furnish plants with a normally developed branch system. Do not furnish plants with disfiguring knots, sun-scald, injuries, abrasions of the bark, dead or dry wood, broken terminal growth, or other objectionable disfigurements. Furnish plants that are without plant diseases or insect pests. Furnish trees with reasonably straight stems and well branched and symmetrical branches according to their natural habits of growth.

Comply with nursery inspection and plant quarantine regulations of the states of origin and destination including Federal regulations governing interstate movement of nursery stock. Provide a valid copy of the certificate of inspection with each package, box, bale, or carload shipped or otherwise delivered.

Fertilizer

Furnish standard commercial grade dry formulated fertilizer conforming to the standards of the Association of Official Analytical Chemists International, applicable Federal and state regulations, and required minimum percentages of available nutrients.

Supply the fertilizer in new, clean, sealed, and properly labeled containers with name, mass, and guaranteed analysis of contents clearly marked.

Liquid fertilizer containing the minimum percentage of available nutrients may be used.

CONSTRUCTION REQUIREMENTS

Do not plant in frozen ground, when snow covers the ground, or when the soil is saturated, extremely dry, cloddy, hard pan, not friable, or is otherwise unsatisfactory for planting.

Furnish stock with a live and fibrous root system. Do not provide container-grown stock that is pot-bound, has a top system out of proportion (larger) than the size of the container, has rooting media that does not hold together when plant is removed from the container, or has roots growing out of the container.

Tag each plant or groups of plants with a weatherproof tag showing species name and date of date of delivery.

Install plants received on site within 5 days. Exceptions may be granted by the Contracting Officer (CO) based on specific project conditions.

Notify the CO 30 days before delivery of material to permit the CO the opportunity to select material at the source. Submit commercial certifications and complete written information concerning the source of supply for plant material at least 14 days before delivery of plants to the project.

Package plants to provide protection against weather and breakage during transit. Tie and cover plants to prevent wind damage and dehydration when transporting by open vehicle. Pack and ventilate plants to prevent sweating when transporting by closed vehicle. Keep bare root plants at a temperature of 32-38°F (0-3°C) during transport.

Keep growing media moist. Protect bark, branches, and root systems from damage. Replace damaged plants including plants with cracked or crushed root balls.

Protect plants not scheduled for immediate planting as follows:

- (a) Keep bare root plants below 35 °F (2 °C);
- (b) Cover the earth balls of balled and burlapped plants with mulch or other suitable material and keep moist;
- (c) Protect container-grown plants from over-exposure to sunlight and keep moist; and
- (d) Protect plants from animals and insects.

Prior to beginning any site work, submit planting locations and methods of planting for approval. At least 14 days prior to planting, mark planting locations with stakes or flagging. Remove sod, weeds, roots, and other unsuitable material from the planting site. Do not leave planting holes open overnight.

Fertilize using either of the following methods:

- (a) Mix the fertilizer with the backfill mixture when it is prepared; or
- (b) Spread the fertilizer uniformly around the pit area of individual plants or over shrub beds. Cultivate the fertilizer into the top 2 inches (50 millimeters) of the backfill mixture.

Water plants during and immediately after planting and throughout the plant establishment period. Saturate the soil around each plant at each watering.

When guying and staking is specified, guy deciduous trees just below the first lateral branch and guy evergreen trees halfway up the height of the tree. Do not leave the guys and stakes on a tree for more than one growing season.

Prune before or immediately after planting to preserve the natural character of each plant. Use experienced personnel to perform the pruning. Use accepted horticultural practice. Prune per ANSI 300 Part 1 standards for structure and form.

Remove weeds and other live vegetation from pit and water basin areas around individual plants and from entire shrub beds. If wood chips are used, do not import without approval from the CO. Place mulch within 24 hours after planting.

ACCEPTANCE

The plant establishment period is a 1-year period beginning at the completion of the project. Employ necessary means to preserve the plants in a healthy growing condition during the plant establishment period. Water, weed, prune, adjust guys and stakes, and protect from animals, insects and disease during the plant establishment period. At the end of the plant establishment period, remove guys and stakes.

An inspection of the plant material will be made about 15 days before the end of the plant establishment period to identify dead, dying, or diseased plants for removal and replacement. During the following planting season, remove and replace identified plants according to this Section and/or at the direction of the CO. A final inspection of all plant material within 15 days after completion of all replacement planting will be the basis for final acceptance.



TREE MAINTENANCE SPECIFICATIONS

DESCRIPTION

This work consists of maintaining vegetation, both existing and new plantings. For new plantings, also refer to specifications under the appropriate section of the Streetscape Construction Manual.

MAINTENANCE REQUIREMENTS

Conform to relevant industry standards for care of nursery stock, including ANSI A300 (Part 6) and ANSI Z60.1 (American Standard for Nursery Stock).

Protect trees during construction and renovation projects according to ANSI A300 (Parts 2, 5, and 8).

Periodically inspect all planting areas and remove fallen leaves, plant debris, and litter as needed.

Perform seasonal maintenance at the beginning of the fall and spring planting seasons, to include:

- (a) Remove and replace dead, diseased, dying, or severely damaged plants. Dead or fatally-damaged plants are those that do not show vigorous, hardy, and sustained growth characteristics on seventy-five (75) percent of the specimen. Dead or fatally-damaged trees are those where the main leader has died back and/or twenty-five (25) percent of the crown does not show vigorous, hardy, and sustained growth. Sustained growth percentages may vary by species; consult a certified arborist as needed to determine plant viability. Ensure trees have no visible cankers, wounds, or holes.
- (b) Apply an organic, slow-release fertilizer only as recommended as a result of soil sample testing.
- (c) Prune trees, shrubs, and groundcovers as follows:
 - i. Street Trees:
 1. Prune street trees that overhang pedestrian pathways to a branching clearing height of eight (8) vertical feet from adjacent finished grade at the time of planting.
 2. Prune street trees that overhang roadways fourteen (14) feet above the adjacent finished grade of the roadway (eighteen (18) feet on a Big Bus Route).
 3. Achieve clearances by judicious pruning and not necessarily removing all limbs along the trunk or main stem of the tree.
 4. Prune trees according to applicable ANSI standards.
 - ii. Shrubs:
 1. Prune shrubs for screening as a mass to enhance their natural form and maintain a vertical height between two (2) and three (3) feet continuous overall.
 - iii. Groundcover:
 1. Prune groundcover to retain its natural growing habit within planting beds or borders. Restrict groundcover from invading or overcoming adjacent paths.
- (d) Remove dead, diseased, insect-infested, or weak wood during the dormant season, after flowering, or as needed to achieve pest or disease control measures.
- (e) Remove excess shoots and suckers.
- (f) Supply trained and certified personnel to perform insect and disease control.

- (g) Install mulch in planting beds, around trees, and to restore planting saucers and bed liners.
- (h) Remove weeds in turfgrass areas and landscape beds and apply weed prevention measures as needed.
- (i) If the site does not have an automatic or semi-automatic watering system, water plantings according to best practices for the individual specimen.

When removing, trimming, or mowing trees or landscape vegetation, minimize disruption of avian and mammal habitat. National Mall and Area (NAMA) Parks are habitat for several avian and mammal species of concern. See *Monumental Core Streetscape Design Guidelines: Vertical and Surface Elements and Appendices*, Appendix A-T-2 NAMA Bird and Bat Best Management Practices, latest edition, for guidance including specific cut-off dates for tree and shrub removal in compliance with the Migratory Bird Treaty Act (1918), The Bald and Golden Eagle Protection Act (1940), and District of Columbia regulations (2015).

Promote tree canopy expansion and healthy tree growth by minimizing conflicts with tree roots and utilities. Mitigate any conflicts between trees and sidewalks, underground utilities, below-grade buildings, and other infrastructure elements.



MULCHED TREE BOX TREATMENT DETAIL

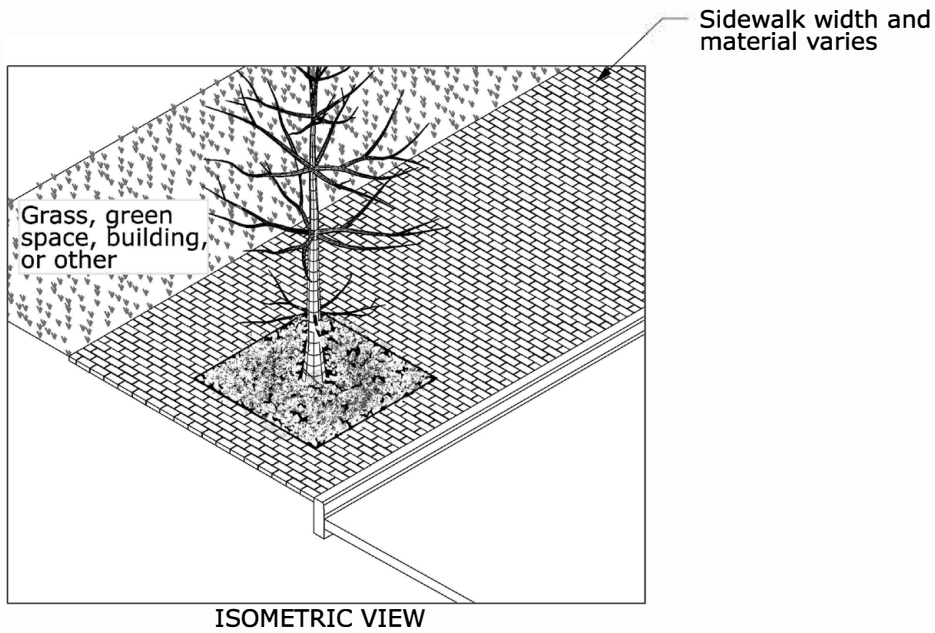

NOTES

1. Surrounding elements (sidewalk, curb, pavement, tree, and green space) shown above may vary. Refer to design plans and surrounding features for specific site layout.
2. Refer to the included specifications for additional guidance and requirements on mulch and plantings.
3. See Tree Planting detail for mulch cross-section.

No Scale

TREE BOX TREATMENT
MULCH ALTERNATIVE
SHEET 1 OF 4

VEGETATED TREE BOX TREATMENT DETAIL

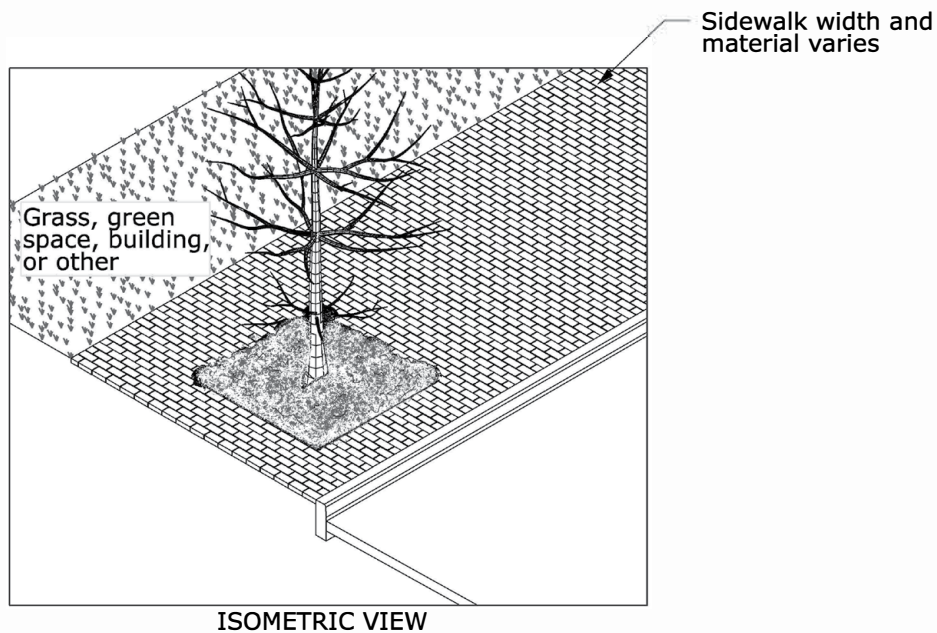

NOTES

1. Surrounding elements (sidewalk, curb, pavement, tree, and green space) shown above may vary. Refer to design plans and surrounding features for specific site layout.
2. Refer to the included specifications for additional guidance and requirements on mulch and plantings.
3. See Tree Planting detail for mulch cross-section.
4. Vegetation type, size, and placement may vary. Supply plantings and install according to the specifications, applicable guidelines, design plans, and at the direction of the COR.

No Scale

TREE BOX TREATMENT
VEGETATION ALTERNATIVE
SHEET 2 OF 4

LOOSE-LAID PAVER TREE BOX TREATMENT DETAIL

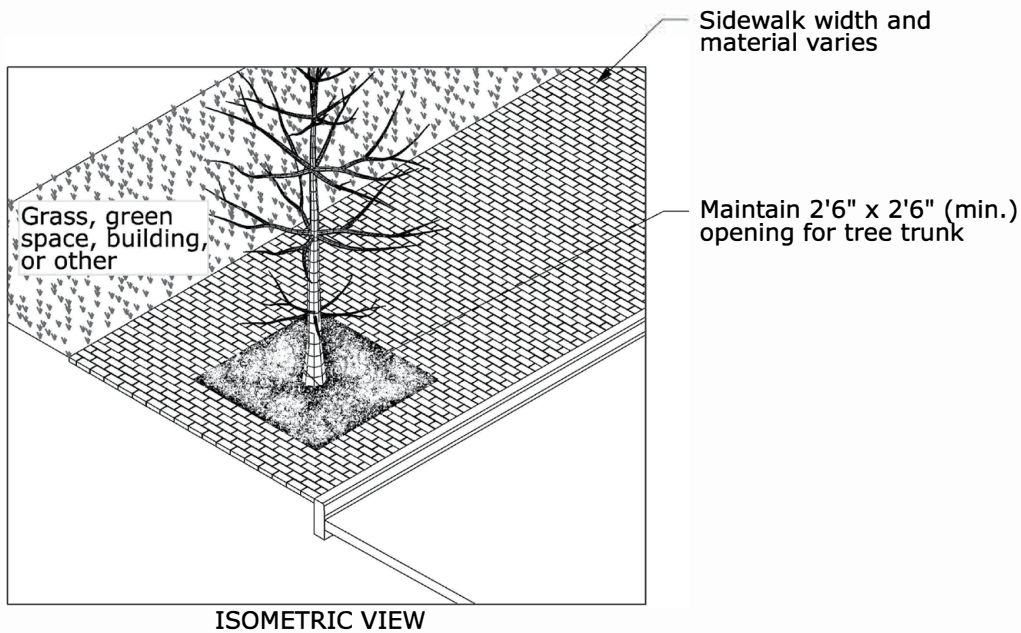

NOTES

1. Surrounding elements (sidewalk, curb, pavement, tree, and green space) shown above may vary. Refer to design plans and surrounding features for specific site layout.
2. Refer to the included specifications for additional guidance and requirements on material types and placement.
3. Install grey granite blocks level with adjacent surface.
4. Do not cut into soil of root ball to achieve level grade for block surface.

Filter fabric wrap to 1/2" below finished grade

Sand setting bed, 1" max. depth

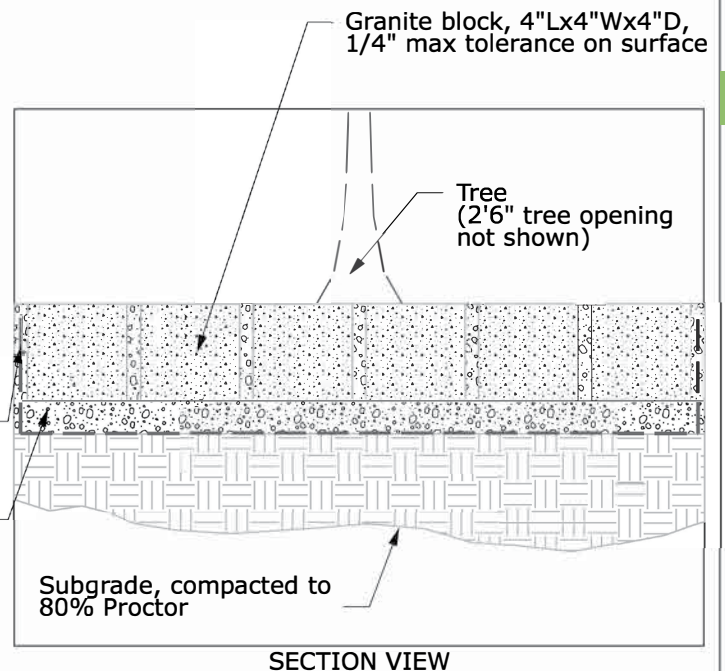

TREE BOX TREATMENT
LOOSE-LAID PAVER ALTERNATIVE
SHEET 3 OF 4

No Scale

FLUSH FLEXIBLE PAVING TREE BOX TREATMENT DETAIL

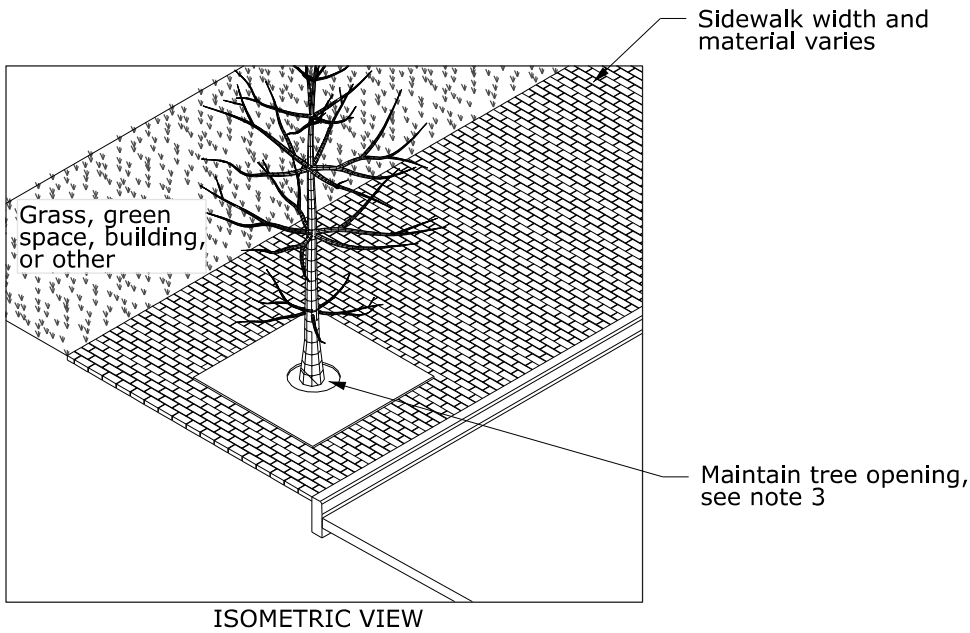

NOTES

1. Surrounding elements (sidewalk, curb, pavement, tree, and green space) shown above may vary. Refer to design plans and surrounding features for specific site layout.
2. Refer to the included specifications for additional guidance and requirements on material types and placement.
3. Construct tree opening with a 1'-3" min. radius, allow sufficient space for tree establishment as directed by the COR.

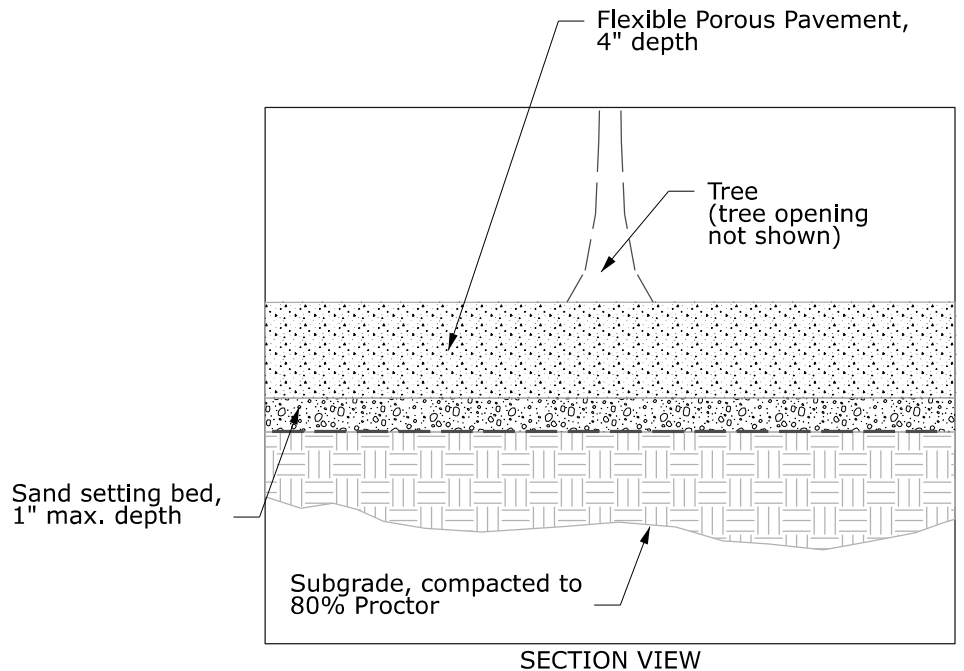

TREE BOX TREATMENT FLEXIBLE PAVEMENT ALTERNATIVE

No Scale

ABOVE GRADE FLEXIBLE PAVING TREE BOX TREATMENT DETAIL

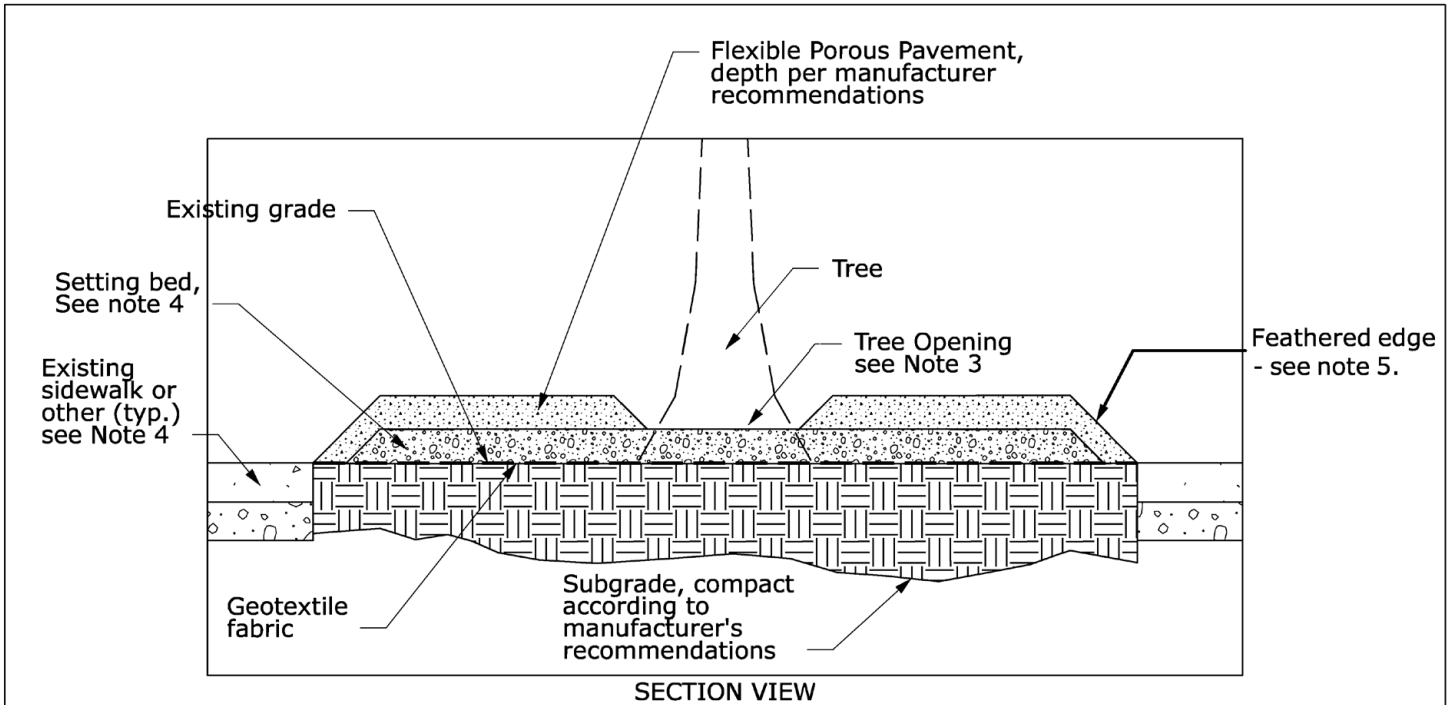

NOTES

1. Surrounding elements (sidewalk, curb, pavement, tree, and green space) shown above may vary. Refer to design plans and surrounding features for specific site layout.
2. Refer to the included specifications for additional guidance and requirements on material types and placement.
3. Construct tree opening with a 1'-3" min. radius allow sufficient space for tree establishment as directed by the CO.
4. Use sand or #57 stone for the setting bed per flexible pavement manufacturer recommendations.
5. Feather flexible paving surface to meet existing adjacent surfaces in flush condition to prevent tripping hazards.
6. Color hues of flexible porous pavement should complement the color of adjacent sidewalk materials such as exposed aggregate. Contrast (lightness/darkness) of flexible porous pavement within tree boxes may differ from adjacent sidewalks to distinguish the tree box zone from pedestrian areas.
7. Add choker layer as required to prevent soil migration.

TREE BOX TREATMENT
FLEXIBLE PAVEMENT ALTERNATIVE
ABOVE-GRADE OPTION

No Scale

TREE BOX TREATMENT SPECIFICATIONS

DESCRIPTION

This work consists of furnishing and placing finishing elements for tree boxes, including mulch, plantings, loose-laid paver stones, and/or flexible pavement.

GUIDELINES

In addition to the design plans and direction of the Contracting Officer (CO), cross-reference the latest edition of the following guidelines:

Monumental Core Streetscape Guide: Vertical and Surface Elements chapters

DC Municipal Regulations Section 24-109, Beautification of Tree Spaces

DDOT Green Infrastructure Standards, Section P (Green Infrastructure Plant List) and Section M (Maintenance Schedules)

DDOT-UFD Tree Preservation Guidance, <https://ddot-urban-forestry-dcgis.hub.arcgis.com/pages/tree-preservation>

DC Department of Energy and Environment *Green Area Ratio Guidebook*, guidance on mulching, plant selection, soils, and soil amendments

ANSI Z60 and A300

In case of conflicts between guidelines, refer to the jurisdiction of the site, design plans, and direction of the CO.

MATERIALS AND CONSTRUCTION

Supply materials conforming to the above guidelines.

For loose-laid pavers, supply pavers meeting the specifications for Pennsylvania Avenue Development Corporation (PADC) Paver Sidewalk. Supply granite type and color visually consistent with roadside granite curbs.

For flexible pavement, supply materials conforming to DDOT Green Infrastructure Standard 621.07. Provide color hues complimenting the color of adjacent sidewalk materials but sufficiently different to distinguish the tree box zone from surrounding pedestrian areas. Submit samples to the CO for approval at least 30 days prior to construction.

Establish perimeter controls to protect the planting site from vehicle and pedestrian traffic until work is complete, approved by the CO, and the tree box is stabilized.

Do not plant in frozen ground, when snow covers the ground, or when the soil is saturated, extremely dry, cloddy, hard pan, not friable, or is otherwise unsatisfactory for planting.

Furnish stock with a live and fibrous root system. Do not provide container-grown stock that is pot-bound, has a top system out of proportion (larger) than the size of the container, has rooting media that does not hold together when plant is removed from the container, or has roots growing out of the container.

Tag each plant or groups of plants with a weatherproof tag showing species name and date of date of delivery.

Install plants received on site within 7 days.

Notify the CO 30 days before delivery of material to permit the CO the opportunity to select material at the source. Submit commercial certifications and complete written information concerning the source of supply for plant material at least 14 days before delivery of plants to the project.

Package plants to provide protection against weather and breakage during transit. Tie and cover plants to prevent wind damage and dehydration when transporting by open vehicle. Pack and ventilate plants to prevent sweating when transporting by closed vehicle. Keep bare root plants between 32 and 38 °F (0-3 °C) during transport.

Keep growing media moist. Protect root systems from damage. Replace damaged plants including plants with cracked or crushed roots.

Perform soil tests and add soil amendments (compost, lime, etc) to address nutrient and/or pH deficiencies as needed and as directed by the CO.

Protect plants not scheduled for immediate planting as follows:

- (a) Keep bare root plants below 35 °F (2 °C);
- (b) Protect container-grown plants from over-exposure to sunlight and keep moist; and
- (d) Protect plants from animals and insects.

At least 14 days before planting, submit planting locations and methods of planting for approval. Mark planting locations with stakes or flagging. Remove sod, weeds, roots, and other unsuitable material from the planting site. Do not leave planting holes open overnight.

If soil amendments are not added, fertilize using either of the following methods as required and as directed by the CO:

- (a) Mix the fertilizer with the backfill mixture when it is prepared; or
- (b) Spread the fertilizer uniformly around the pit area of individual plants or over shrub beds. Cultivate the fertilizer into the top 2 inches (50 millimeters) of the backfill mixture.

After planting, stabilize plants as required by supplier guidelines and site conditions using rubber hose and wires, ArborTies or approved equal, or other best practices.

Water plants during and immediately after planting and throughout the plant establishment period according to supplier guidelines for the individual plant species.

Prune before or immediately after planting to preserve the natural character of each plant. Use experienced personnel to perform the pruning. Use accepted horticultural practice.

Remove weeds and other live vegetation from pit and water basin areas around individual plants and from entire shrub beds. If wood chips are used, do not import without approval from the CO. Place mulch within 24 hours after planting.

ACCEPTANCE

The plant establishment period is a 1-year period beginning at the completion of the project. Employ necessary means to preserve the plants in a healthy growing condition during the plant establishment period. Water, weed, prune, adjust guys and stakes, and protect from animals, insects and disease during the plant establishment period. At the end of the plant establishment period, remove guys and stakes.

An inspection of the plant material will be made about 15 days before the end of the plant establishment period to identify dead, dying, or diseased plants for removal and replacement. During the following planting season, remove and replace identified plants according to this Section and/or at the direction of the CO. A final inspection of all plant material within 15 days after completion of all replacement planting will be the basis for final acceptance.



STRUCTURAL SOIL DETAIL

NOTES

1. Minimum open tree planting space dimensions: 4'x6'
2. Maximum watershed area: 6.0 times area of the open tree planting area.
3. See DDOT Dwg no. 621.74 for bottom sand layer and subsurface drainage requirements.
4. For sidewalk over structural soil detail options, see Sidewalk Details.
5. For tree installation requirements, see Tree Planting Details.
6. Curb shown but may not be used in all areas. Refer to plans and Curb Details
7. Add drains as needed to allow air and water into soil beneath adjacent surfaces if width is greater than 10'.

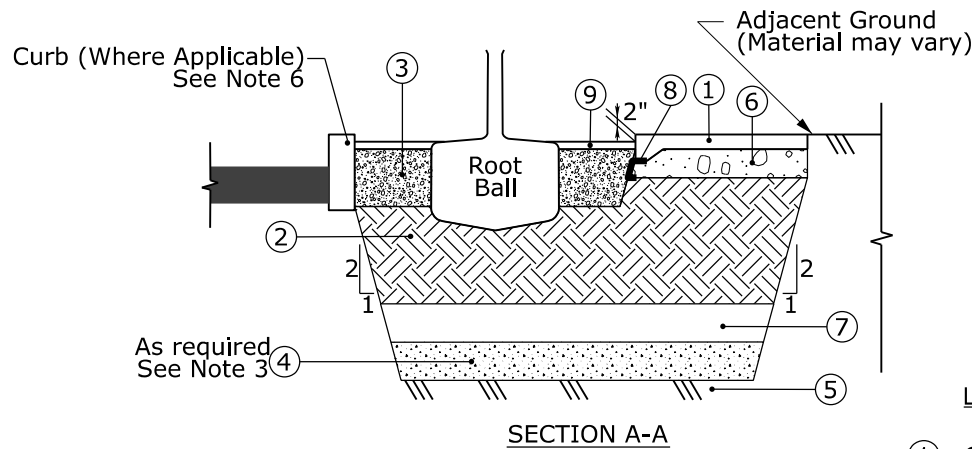
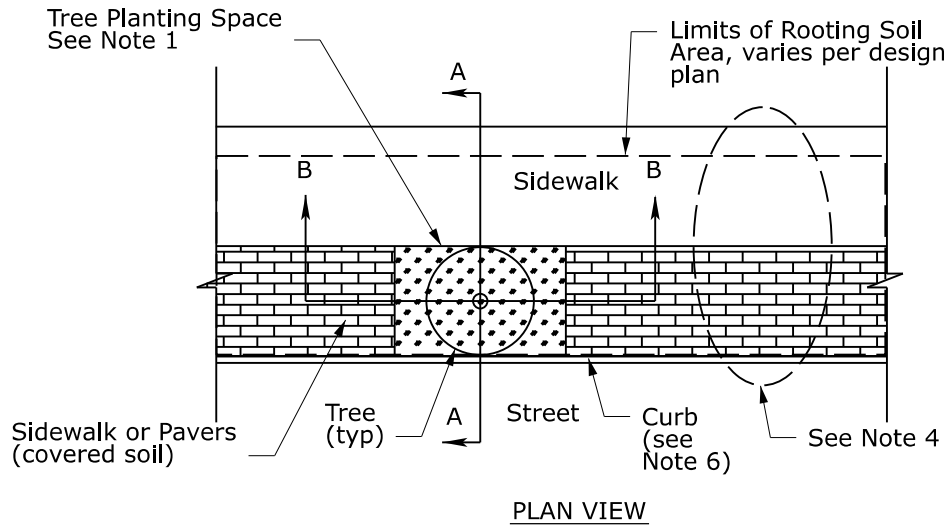

LEGEND

- ① Sidewalk/Pavers
- ② DDOT-approved structural soil, 30" min.
- ③ Planting soil - 12" depth
- ④ Sand - up to 12" (as required)
- ⑤ Scarified subsoil - 4"
- ⑥ Crushed stone, double-washed, no. 57 - 6"
- ⑦ Choker layer
- ⑧ Geotextile
- ⑨ Mulch - 3"

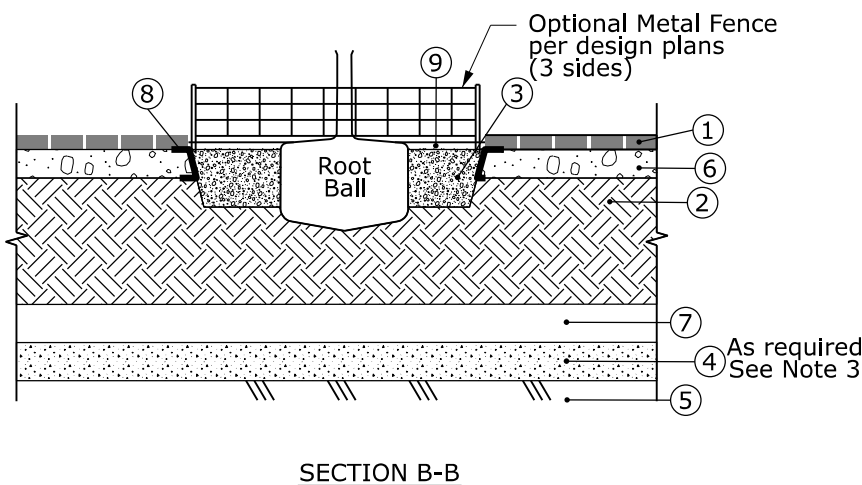

STRUCTURAL SOIL UNDER SIDEWALK - COVERED TREE SPACE

No Scale

*Adapted from DDOT Dwg. No. 621.70

STRUCTURAL SOILS SPECIFICATIONS

DESCRIPTION

This work consists of constructing structural soils to support installation of trees and other landscape features.

MATERIAL

Planting Soil

Furnish fertile, friable, free draining, sandy loam soil that is free of subsoil, refuse, stumps, roots, brush, weeds, rocks larger than 1 inch (25 millimeters), or other substances detrimental to the development of vegetative growth. Demonstrate that the soil can sustain healthy crops of grass, shrubs, or other plant growth. Conform to the following:

- | | |
|----------------------------------|---------------------|
| (1) Texture | |
| (a) Organic matter, AASHTO T 267 | 3.0 to 10.0 percent |
| (b) Sand, AASHTO T 88 | 20 to 70 percent |
| (c) Silt, AASHTO T 88 | 10 to 60 percent |
| (d) Clay, AASHTO T 88 | 5 to 30 percent |
| (2) pH, AASHTO T 289 | 6.0 to 8.0 |

For soil volume, conform to the latest version of the following:

- (1) DDOT Design and Engineering Manual, Section 37.5.3, Minimum Soil Volumes
- (2) DDOT Green Infrastructure Standards, Section 47.7.1
- (3) DDOT Public Realm Design Manual (PRDM), Section 3.6

Supply minimum soil volumes as follows:

- | | |
|--|--|
| (1) For large trees (60-80 feet tall) | 1,500cuft soil within a 27-foot radius |
| (2) For medium trees (40-60 feet tall) | 1,000cuft soil within a 22-foot radius |
| (3) For small trees (less than 40 feet tall) | 600cuft soil within a 16-foot radius |

Crushed Aggregate

Furnish hard, durable particles or fragments of crushed stone or gravel conforming to the size and quality requirements for crushed aggregate material normally used locally in the construction and maintenance of highways by Federal or state agencies. Furnish crushed aggregate with a maximum size of 1 inch (25 millimeters) as determined by AASHTO T 27 and AASHTO T 11. Furnish crushed aggregate uniformly graded from coarse to fine and free of organic matter, lumps or balls of clay, and other deleterious material.

Sand

Furnish clean material conforming to the following:

- | | |
|--------------------------|---------------------|
| (1) Gradation | AASHTO M 6 |
| (2) Deleterious material | AASHTO M 6, Class B |

Structural Soil

Furnish a suitable, free draining material conforming to the following:

- | | |
|---|-------------------|
| (a) Maximum particle size | 3 in (75 mm) |
| (b) Material passing No. 200 (75- μ m) sieve, AASHTO T 27 and AASHTO T 11 | 15.0 percent max. |

(c) Plasticity index, AASHTO T 90

6 max.

Mulch

(a) Straw. Furnish certified weed free straw from oats, wheat, rye, rice, or other grain crops that is without mold or other objectionable material. Furnish straw in an air-dry condition suitable for placing with mulch blower equipment.

(b) Wood fiber. Furnish processed wood fiber from wood chips conforming to the following:

- (1) Colored with a green dye noninjurious to plant growth;
- (2) Readily dispersible in water;
- (3) Nontoxic to seed or other plant material;
- (4) Free of growth or germination inhibiting substances;
- (5) Free of weed seed;
- (6) Air dried to an moisture content of 12 ± 3 percent;
- (7) Packaged in new labeled containers with the manufacturer's name; and
- (8) Packaged in a condition appropriate for mixing in a homogeneous slurry suitable for application with power spray equipment.

(c) Wood chips. Provide wood chips from local sources including clearing. Maximum size of chips is 4 by 2 by $\frac{1}{2}$ inches (100 by 50 by 13 millimeters).

Geotextile

Furnish non-woven geotextile fabric conforming to FHWA *Standard Specifications for Construction of Roads and Bridges on Federal Highway Projects*, Latest Version, Table 714-1.

Fertilizer

Supply fertilizer to amend soil to provide adequate nutrients and micronutrients. Consult requirements of individual plant species for correct types/amounts of fertilizer.

CONSTRUCTION REQUIREMENTS

Do not work with frozen ground, when snow covers the ground, or when the soil is saturated, extremely dry, cloddy, hard pan, not friable, or is otherwise unsatisfactory.

Notify the Contracting Officer (CO) 30 days before delivery of material to permit the CO the opportunity to select material at the source.

When scarifying subsoil, use a rotary mixer with direct water injection capabilities to adequately blend the material and to produce a homogeneous mixture within 2 percent of the optimum moisture content.

ACCEPTANCE

The plant establishment period is a 1-year period beginning at the completion of the project. Employ necessary means to preserve the plants in a healthy growing condition during the plant establishment period. Water, weed, prune, adjust guys and stakes, and protect from animals, insects and disease during the plant establishment period. At the end of the plant establishment period, remove guys and stakes.

An inspection of the plant material will be made about 15 days before the end of the plant establishment period to identify dead, dying, or diseased plants for removal and replacement. During the following planting season, remove and replace identified plants according to this Section and/or at the direction of the CO. A final inspection of all plant material within 15 days after completion of all replacement planting will be the basis for final acceptance.

BIORETENTION PLANTER DETAIL

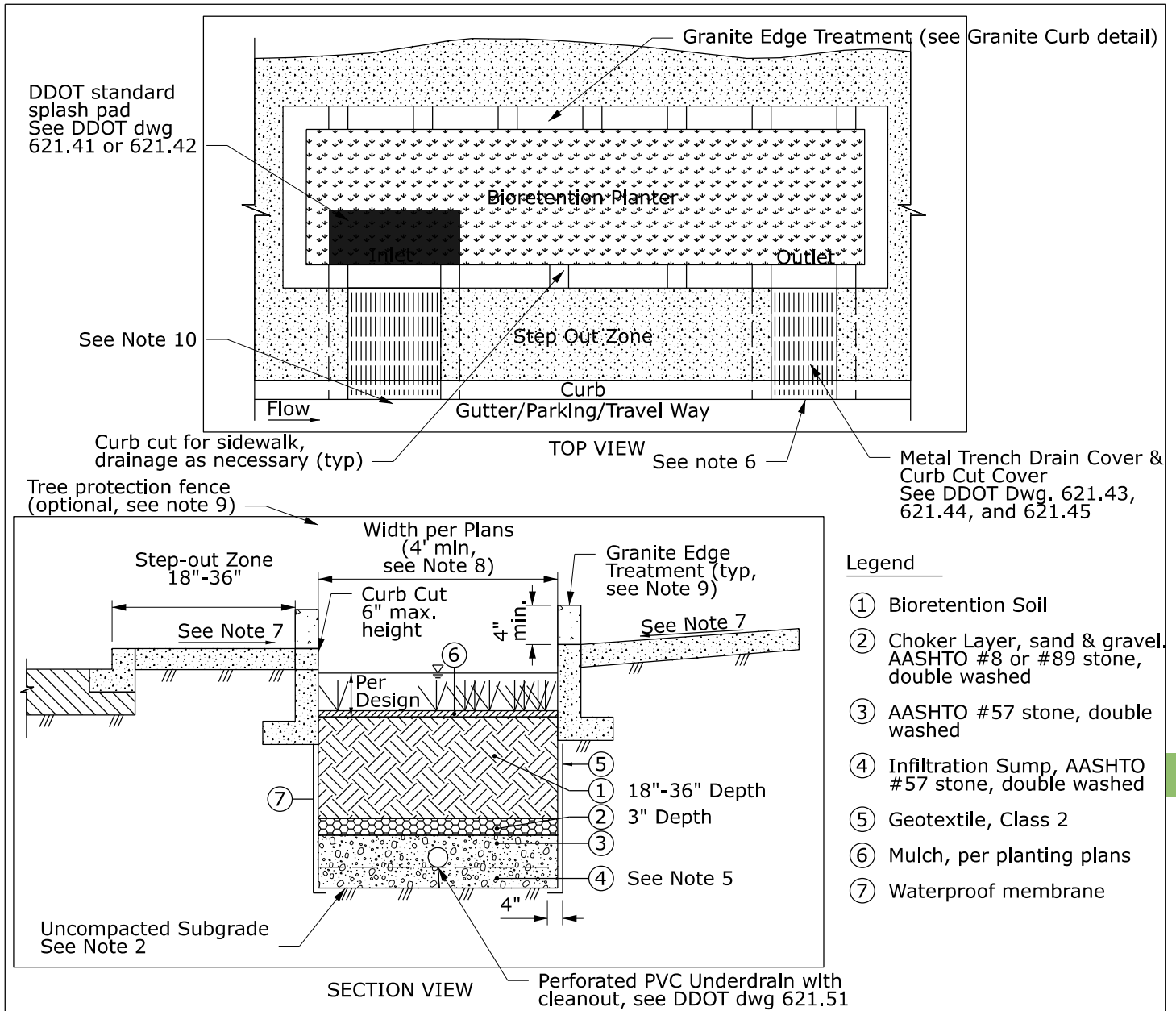

NOTES

1. Refer to and conform to specifications for materials and construction of plantings and structural soils
2. Scarify subgrade 3" min. prior to installation
3. Install trees and plantings according to Streetscape details and specifications, design plans, manufacturer instructions, and at the direction of the COR.
4. Construct bottom of bioretention at least 2' above bedrock and the seasonal high water table as determined by geotechnical investigation.
5. Size depth of infiltration sump to address stormwater management requirements as shown on design plans.
6. Outlet required as specified in plans. If outlet is not used, install overflow drain according to DDOT dwg 621.50.
7. Slope sidewalk toward curb cuts, 1% slope or as shown on design plans.
8. For bioretention planters with trees, construct to a minimum width of 6'.
9. Tree protection fence is optional; see design plans. If tree protection fence is included, raised curb is not required.
10. Size inlet to fit site-specific stormwater requirements.

BIORETENTION PLANTER ADJACENT TO ROADWAY

No Scale

*Adapted from DDOT Drawing No. 621.23

BIORETENTION PLANTER SPECIFICATIONS

DESCRIPTION

This work consists of constructing bioretention planters, including soil, drainage stone, and plantings.

MATERIALS AND CONSTRUCTION

Supply materials conforming to this detail, details of the individual components, design plans, and requirements of the local jurisdiction. Construct individual components as shown in this detail and as shown in the referenced details.

Establish perimeter controls to protect the site from vehicle and pedestrian traffic until work is complete, approved by the Contracting Officer (CO), and the planter is stabilized.

At least 14 days before planting, submit planting locations and methods of planting for approval. Mark planting locations with stakes or flagging. Remove sod, weeds, roots, and other unsuitable material from the planting site. Do not leave planting holes open overnight.

Water plants during and immediately after planting and throughout the plant establishment period. Saturate the soil around each plant at each watering.

Prune before or immediately after planting to preserve the natural character of each plant. Use experienced personnel to perform the pruning. Use accepted horticultural practice.

Remove weeds and other live vegetation from pit and water basin areas around individual plants and from entire shrub beds. If wood chips are used, do not import without approval from the CO. Place mulch within 24 hours after planting.

ACCEPTANCE

The plant establishment period is a 1-year period beginning at the completion of the project. Employ necessary means to preserve plantings in a healthy growing condition during the plant establishment period. Water, weed, prune, adjust guys and stakes (if trees are included), and protect from animals, insects and disease during the plant establishment period. At the end of the plant establishment period, remove guys and stakes.

An inspection of the plant material will be made about 15 days before the end of the plant establishment period to identify dead, dying, or diseased plants for removal and replacement. During the following planting season, remove and replace identified plants according to this Section and/or at the direction of the CO. A final inspection of all plant material within 15 days after completion of all replacement planting will be the basis for final acceptance.

STREET TREE FENCE DETAIL

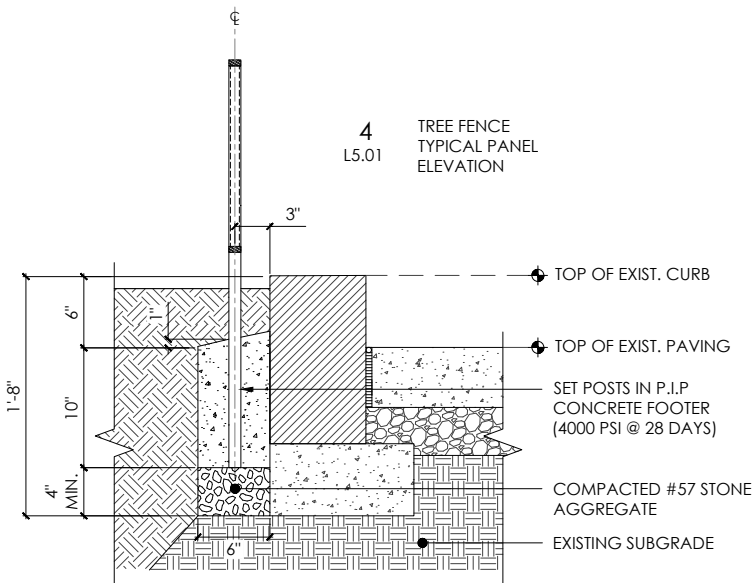

CROSS SECTION

NOTES:

1. HAND DIG ALL FOOTING HOLES TO A WIDTH NO GREATER THAN 12" X 12".
2. CLEANLY SEVER ANY EXPOSED ROOTS DURING EXCAVATION WITH LOPPERS OR HAND SAW.

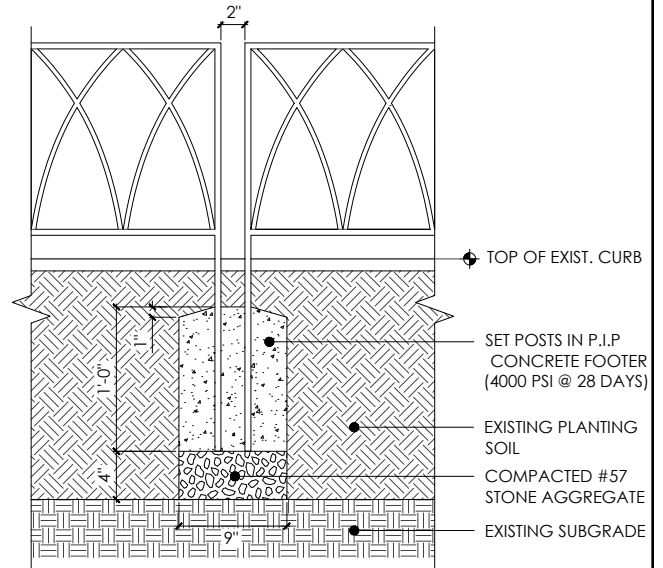

LONGITUDINAL SECTION - FOOTER AT DOUBLE POSTS

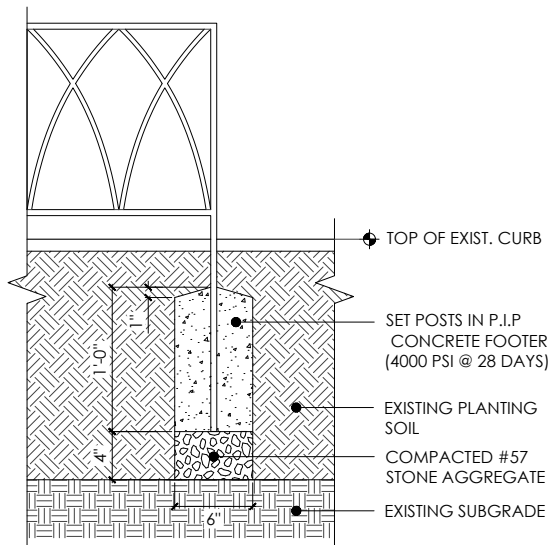

LONGITUDINAL SECTION - FOOTER AT SINGLE POST

TREE FENCE FOOTER, TYPICAL, NOT TO SCALE

STREET TREE FENCE DETAIL

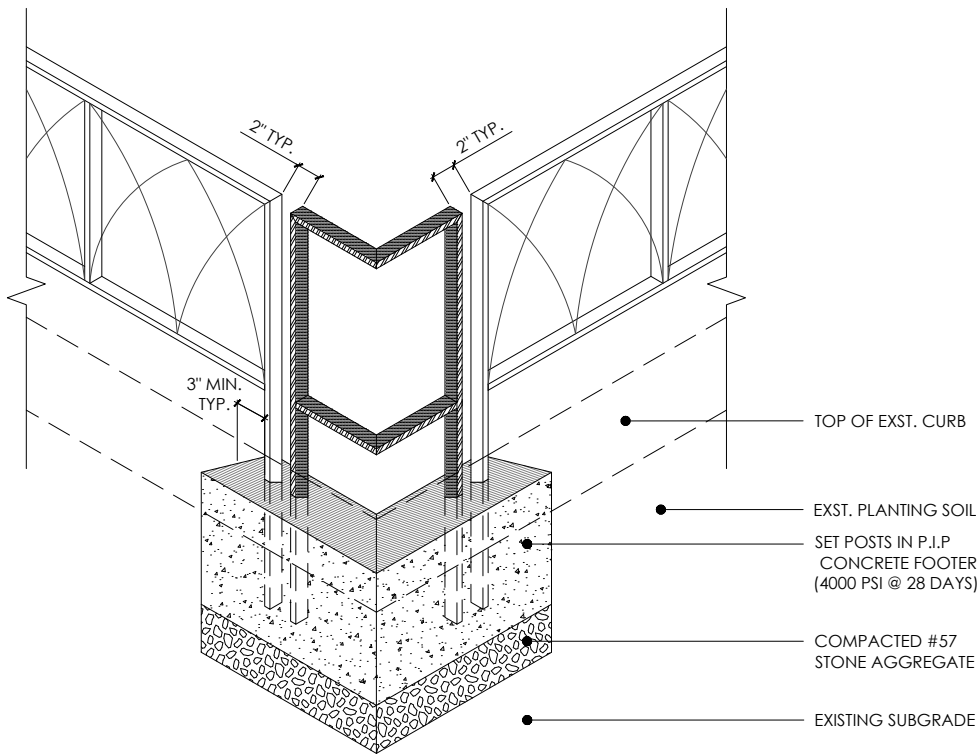

TREE FENCE CORNER

STREET TREE FENCE DETAIL

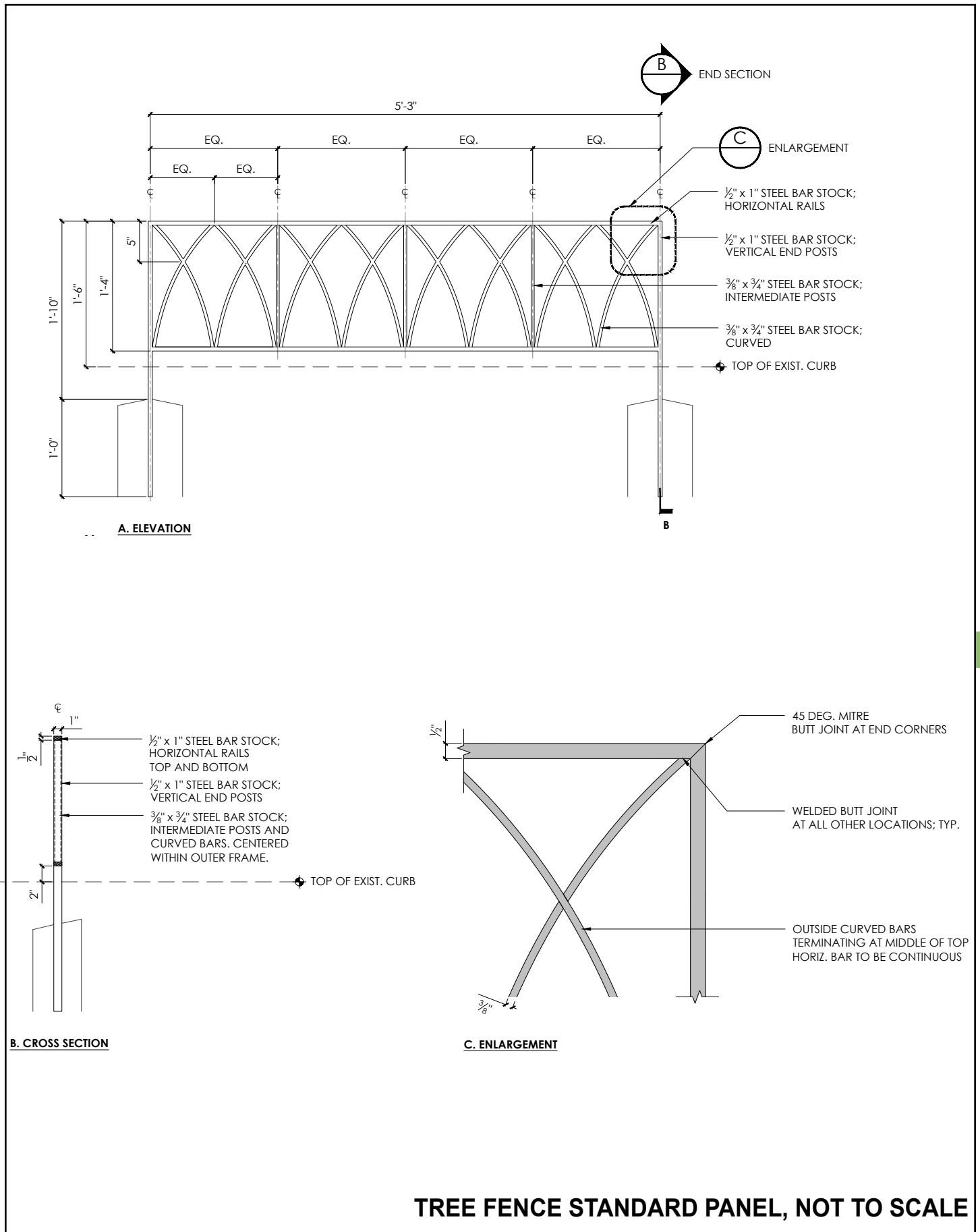

STREET TREE FENCE DETAIL

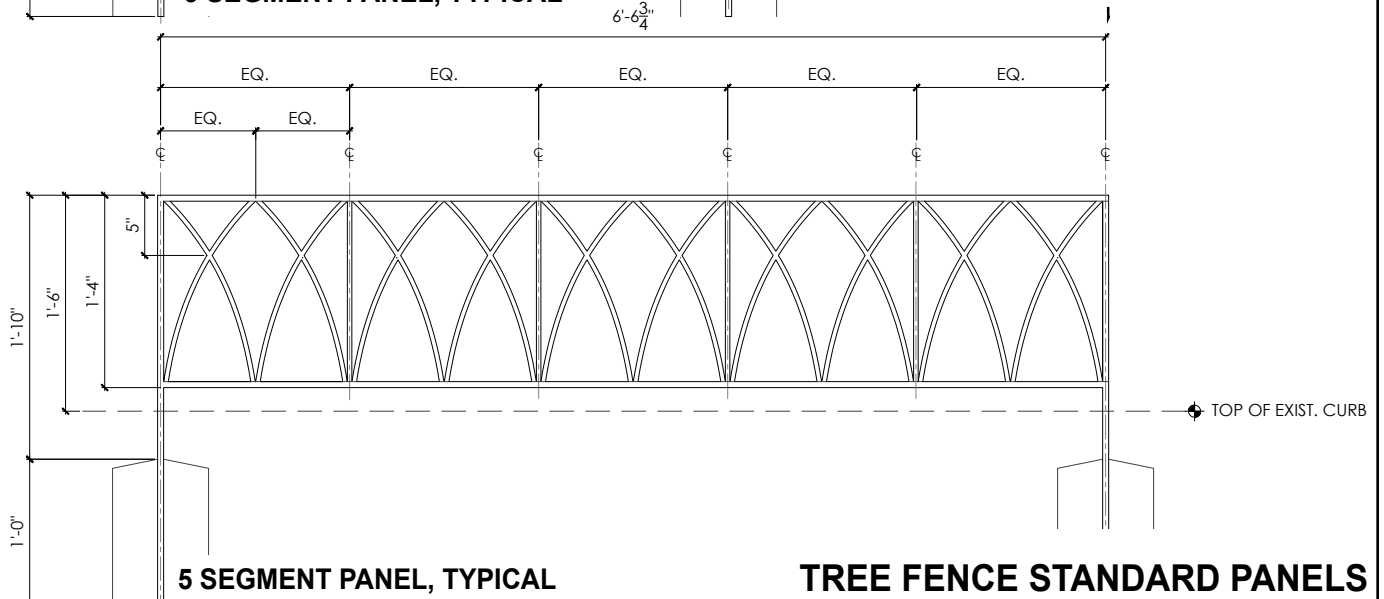
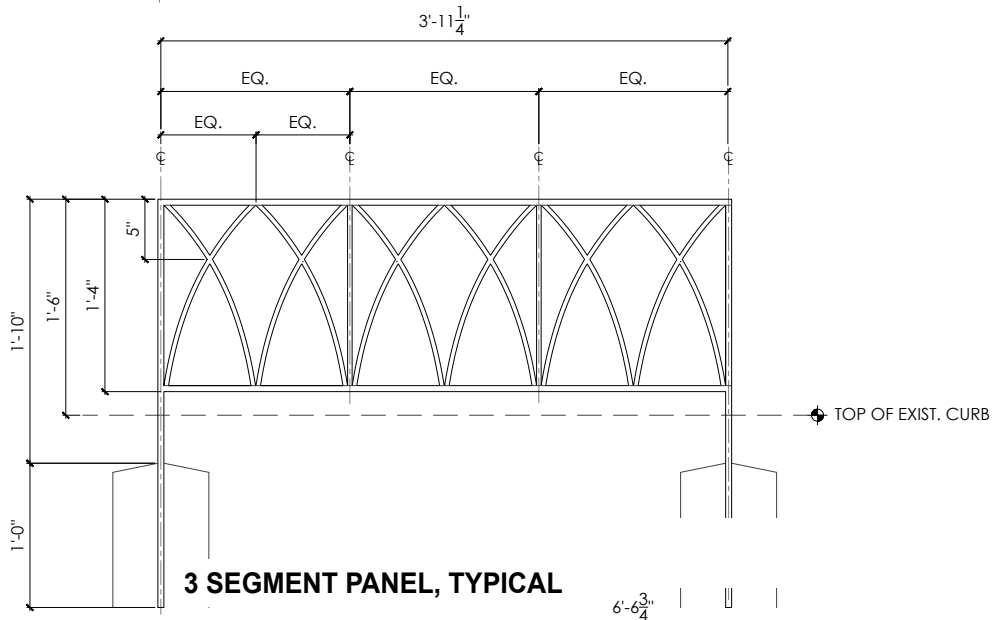
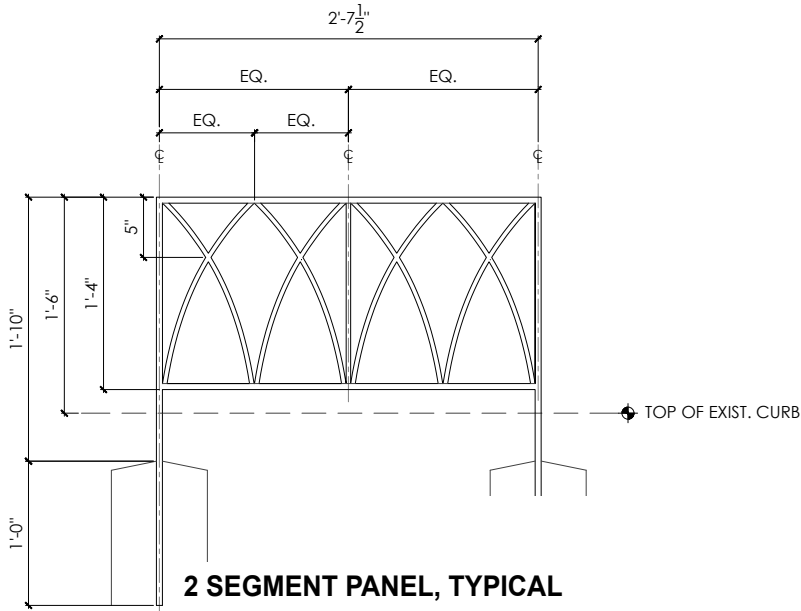

TREE FENCE STANDARD PANELS

STREET TREE FENCE SPECIFICATIONS

DESCRIPTION

This work consists of street tree fencing around the Mall Museums Character Sub-Area.

MATERIAL

Steel and Iron

Furnish hot-rolled, carbon steel bars complying with ASTM A 29/A 29M, Grade 1010.

High Performance Exterior Coating

Furnish hot dipped galvanized primer for steel. Galvanizing bath shall contain special high-grade zinc and other earthy materials. Prepare surface by carefully grinding any bumps, runs, and drips to a relatively smooth surface. Comply with ASTM A 123 for fabricated products and ASTM A 153 for hardware.

Furnish water-based primer over galvanized steel: Following galvanization, all steel to receive (1) coat of factory-applied primer.

1. Primer shall be certified OTC/VOC compliant at less than 2.8 lbs/gallon and conform to EPA and local requirements.
2. Primer shall be compatible with galvanized steel and intermediate and topcoat products. Verify with manufacturer.
3. Primer shall be applied at 5-10 wet mils (2-4 dry mils) DFT and meet or exceed the following performance criteria as stipulated by the coatings manufacturer:

Furnish intermediate coat: Provide (1) factory applied intermediate coat in black color. Apply with airless spray or as recommended by manufacturer.

Furnish topcoat: Provide (2) factory applied topcoats in black color. Apply with airless spray or as recommended by manufacturer.

Concrete Footers

Furnish dry, packaged, normal-weight concrete mix complying with ASTM C 387 mixed with potable water according to manufacturer's written instructions.

Grout

Furnish nonshrink grout, factory-packaged, nonstaining, noncorrosive, nongaseous grout complying with ASTM C 1107 and specifically recommended by manufacturer for exterior applications.

CONSTRUCTION REQUIREMENTS

Construct fence according to design plans. Install work per approved shop drawings.

Lighting

TWIN-TWENTY LIGHT STANDARD DETAIL

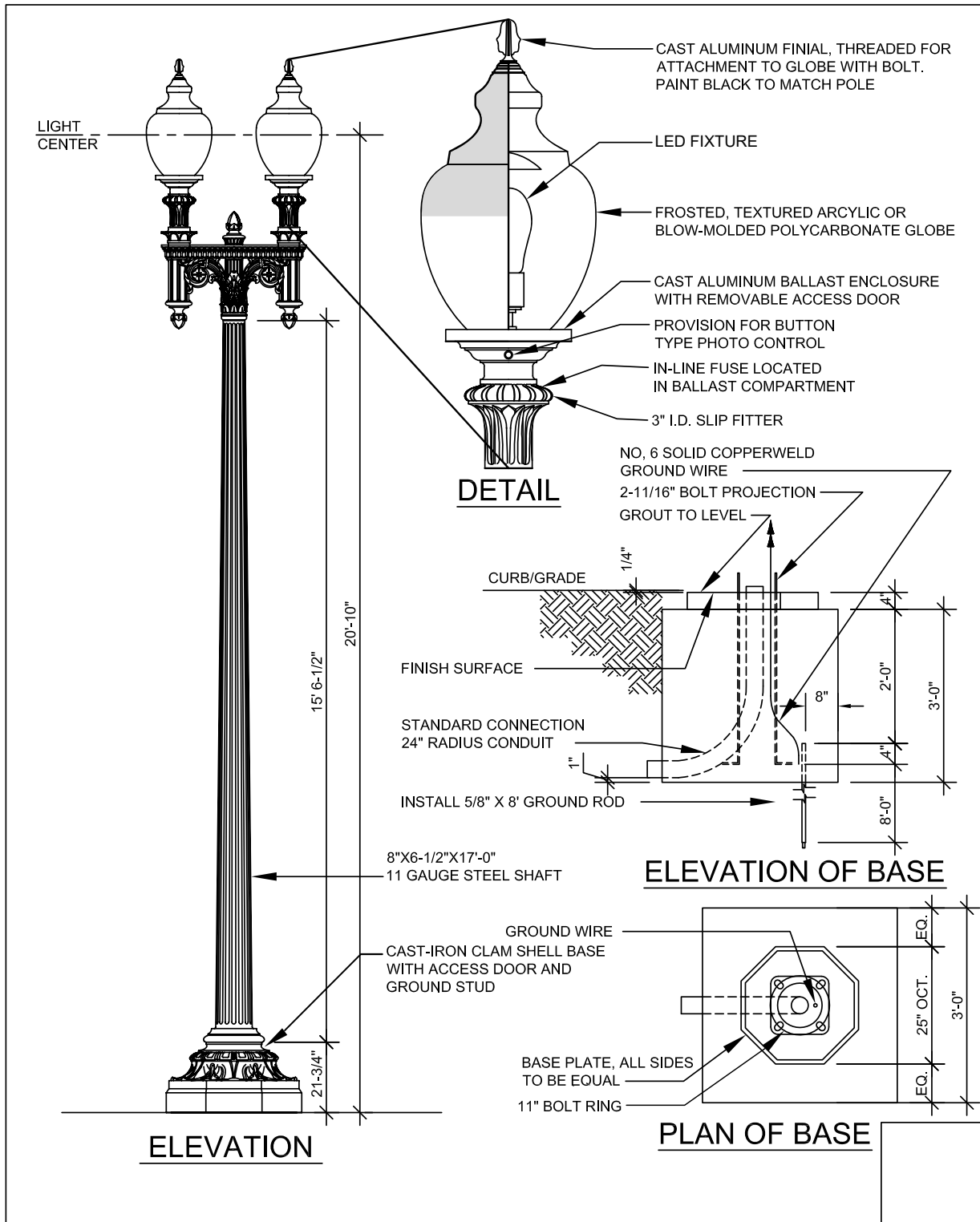

NOTE: SEE MONUMENTAL CORE LED STREETLIGHT PERFORMANCE CRITERIA FOR TECHNICAL LIGHTING GUIDANCE FOR LED LUMINAIRES AND FIXTURES. GUIDANCE FROM THE LED STREETLIGHT PERFORMANCE CRITERIA SHALL SUPERSEDE ANY TECHNICAL INFORMATION INCLUDED WITHIN THIS DETAIL.

WASHINGTON GLOBE #16 LIGHT STANDARD DETAIL

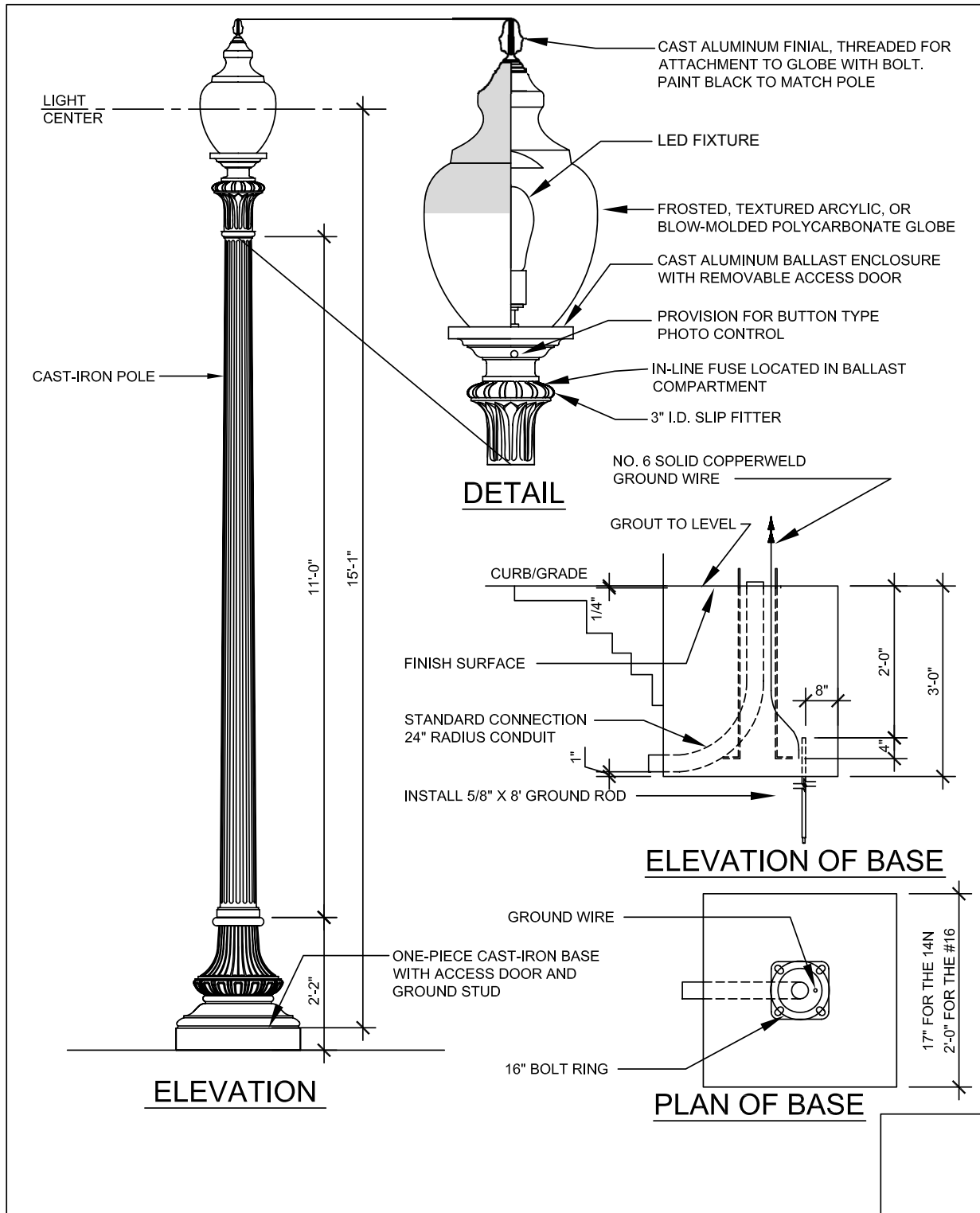

NOTE: SEE MONUMENTAL CORE LED STREETLIGHT PERFORMANCE CRITERIA FOR TECHNICAL LIGHTING GUIDANCE FOR LED LUMINAIRES AND FIXTURES. GUIDANCE FROM THE LED STREETLIGHT PERFORMANCE CRITERIA SHALL SUPERSEDE ANY TECHNICAL INFORMATION INCLUDED WITHIN THIS DETAIL.

WASHINGTON GLOBE #14N LIGHT STANDARD DETAIL

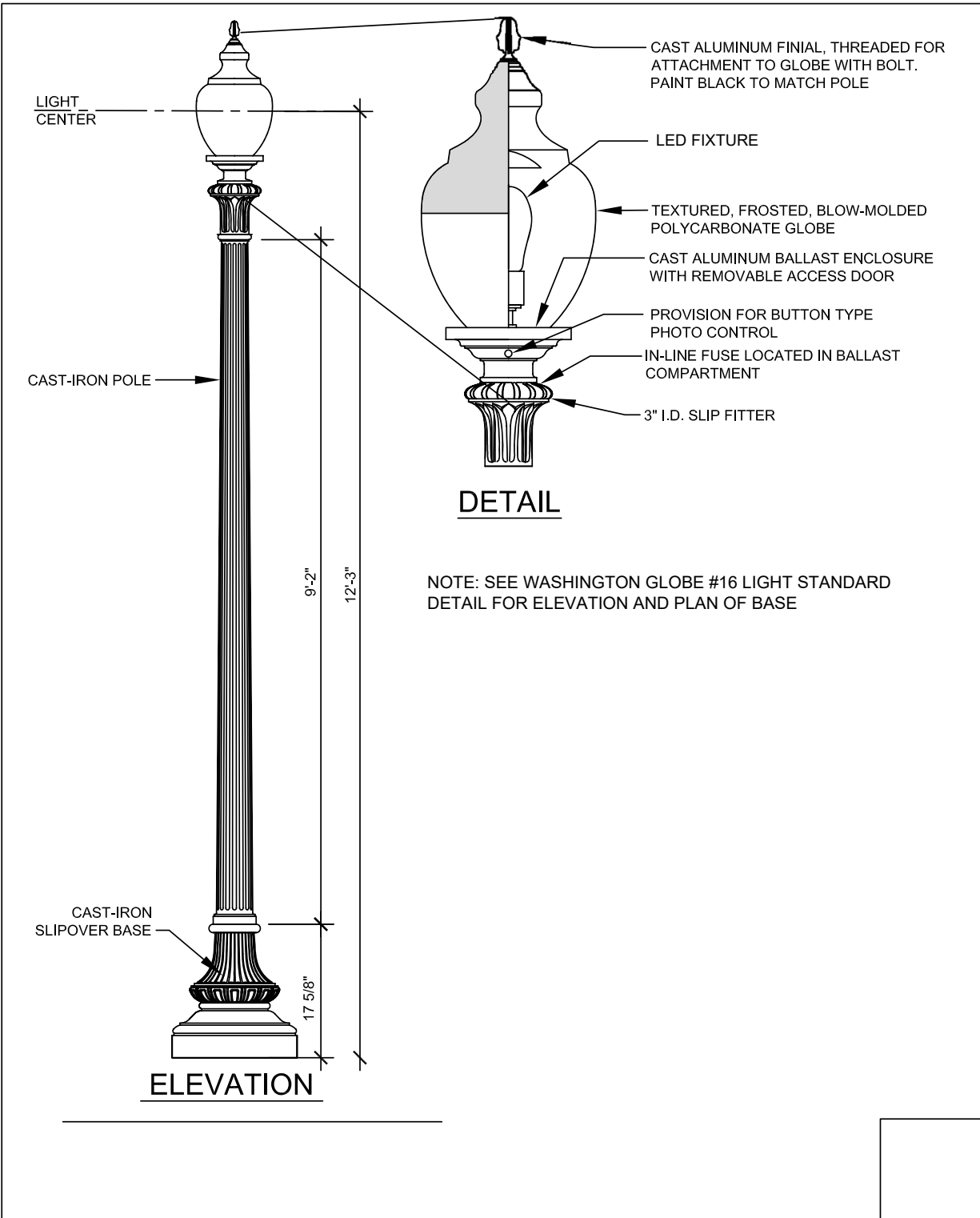

NOTE: SEE MONUMENTAL CORE LED STREETLIGHT PERFORMANCE CRITERIA FOR TECHNICAL LIGHTING GUIDANCE FOR LED LUMINAIRES AND FIXTURES. GUIDANCE FROM THE LED STREETLIGHT PERFORMANCE CRITERIA SHALL SUPERSEDE ANY TECHNICAL INFORMATION INCLUDED WITHIN THIS DETAIL.

FREDERICK LAW OLMSTED LIGHT STANDARD DETAIL

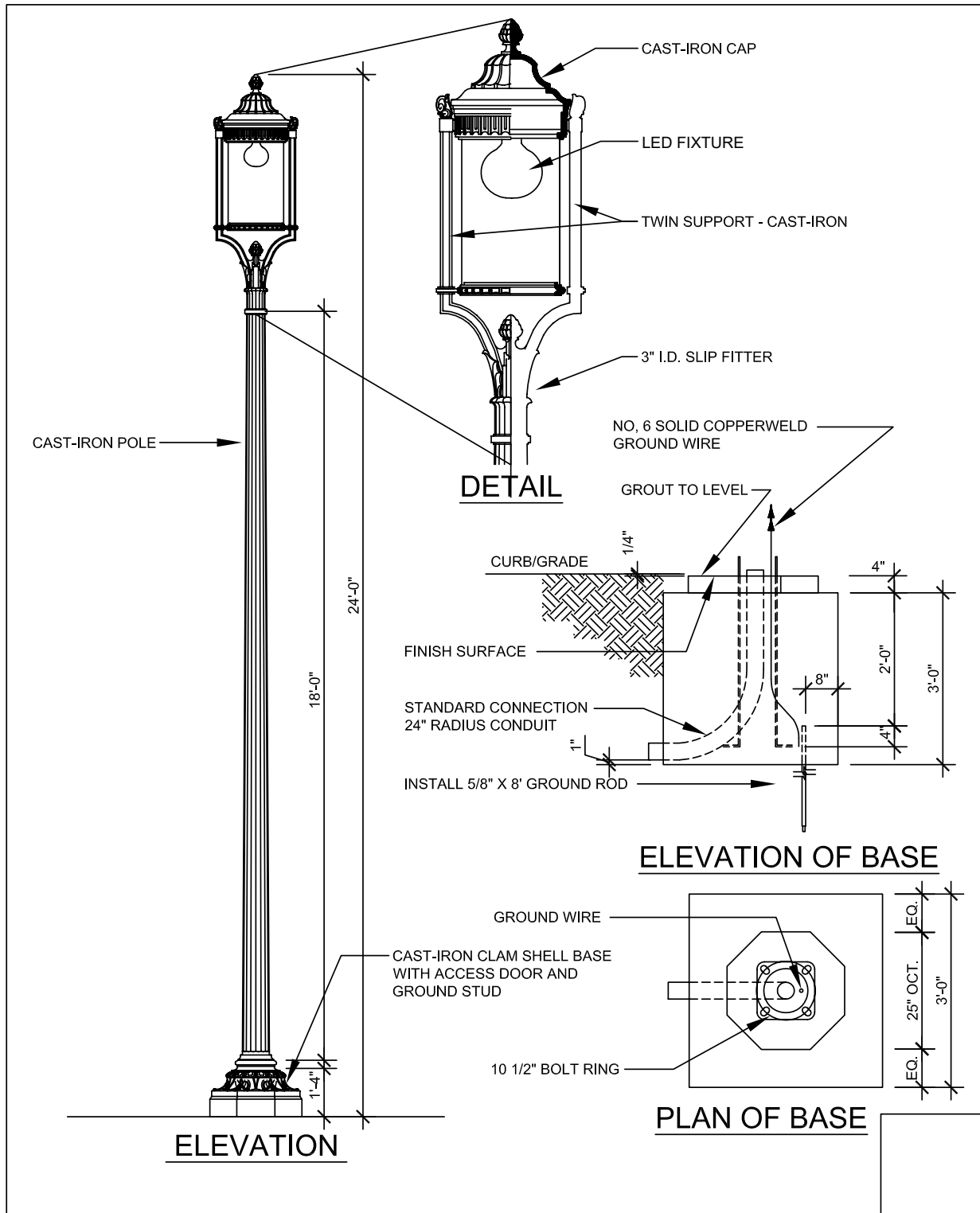

NOTE: SEE MONUMENTAL CORE LED STREETLIGHT PERFORMANCE CRITERIA FOR TECHNICAL LIGHTING GUIDANCE FOR LED LUMINAIRES AND FIXTURES. GUIDANCE FROM THE LED STREETLIGHT PERFORMANCE CRITERIA SHALL SUPERSEDE ANY TECHNICAL INFORMATION INCLUDED WITHIN THIS DETAIL.

LIGHT STANDARD SPECIFICATIONS

DESCRIPTION

This work consists of installing Light-Emitting Diode (LED) street lights.

MATERIAL

Submit LED luminaire, pole, base, foundation and electrical materials conforming to the Monumental Core Construction Manual and Monumental Core LED Streetlight Performance Criteria details, project plans, and specifications of the jurisdiction administering the project as approved by the Contracting Officer (CO).

LAMPPOST STYLES

Manufacture all posts in accordance with the AASHTO “Standard Specifications for the Structural Supports for Highway Signs, Luminaries, and Traffic Signals”.

See Monumental Core Streetscape Guide and Monumental Core LED Streetlight Performance Criteria for more lamppost location guidance.

Twin-Twenty Lamppost

Supply D.C. standard street light, type 2C, TWIN A, with foundation and luminaries.

Paint base, post, and cross-arm with two coats of iron oxide primer inside and out and two finish coats of rust inhibitive or rust preventative black paint to match surrounding street lights or as directed by the CO.

Washington #16 Lamppost

Supply cast-iron lamppost of two-piece construction as shown within the Monumental Core Construction Manual Washington #16 Lamppost Detail. Machine components for interchangeability per DCDPW standards.

Paint all castings with two coats of iron oxide primer inside and out and two finish coats of rust inhibitive or rust preventative black paint to match surrounding street lights.

Washington #14N Lamppost

Supply Washington Globe 14N cast-iron lamppost of two-piece construction as shown within the Monumental Core Construction Manual Washington #14N Lamppost Detail. Machine components for interchangeability per DCDPW standards.

Paint all castings with two coats of iron oxide primer inside and out and two finish coats of rust inhibitive or rust preventative black paint to match surrounding street lights or as directed by the CO.

Frederick Law Olmsted Lamppost

Supply Frederick Law Olmsted lampposts consisting of a two-piece base and column construction as shown within the Monumental Core Construction Manual Frederick Law Olmsted Lamppost Detail.

Supply a cast-iron slipover base conforming to ASTM A 48-82. Manufacture the shaft or column portion of the post of a minimum of 7-gauge steel, 18 feet high with a taper of 0.14 inches per foot.

Supply a tube of monotube construction formed from one-piece, 7-gauge steel without any sectional horizontal welds other than the weld at the base plate. Supply a steel base plate at the bottom of the post that is double-welded to the steel shaft. Supply shaft with one longitudinal electrical weld, which shall be ground smooth after fabrication. After welding, cold roll the shaft and form with 16 Doric flutes equally spaced.

Paint all castings with two coats of iron oxide primer inside and out and two finish coats of rust inhibitive or rust preventative bronzetone paint to match surrounding street lights or as directed by the CO.

CONSTRUCTION REQUIREMENTS

General

At the preconstruction conference, submit a certified cost breakdown of items involved in the lump sum for use in making progress payments and price adjustments.

Furnish materials and workmanship that conform to the standards of the National Electrical Code (NEC), local safety code, UL, and NEMA. Ensure that installers are properly certified prior to beginning work and provide copies of certifications to the CO upon request.

Obtain permits, arrange for inspections, and pay all fees necessary to obtain electrical service.

Notify the local traffic enforcement agency, local utility company, or railroad company, one (1) week before any operational shutdown to coordinate connections or disconnections to an existing utility or system.

Fifteen (15) days before installation, submit a list of proposed equipment and materials. Include the manufacturer's name, size, and identification number of each item. Supplement the list with scale drawings, catalog cuts, and wiring diagrams showing locations and details of equipment and wiring. Provide certified photometric test data from an independent testing laboratory on the proposed lantern, as well as a computer readout that indicates light levels and a uniformity ratio for the area to be lit, for approval of the CO. Provide point-by-point foot-candle printouts of the entire area for evaluation indicating maintained light levels (light loss factor [LLF] = 0.70) uniformity, maximum, minimum, and average and obtain approval prior to installation.

The CO will establish the exact location of systems.

Where roadways are to remain open to traffic and existing systems will be modified, maintain the existing system in operation until the final connection to the modified circuit to minimize traffic disruptions.

Conduit

Install conduit according to national and local electrical codes and applicable laws.

Installation of Lighting Systems

See the Monumental Core LED Streetlight Performance Criteria for technical information on luminaires and fixtures. Install luminaires in accordance with the manufacturer's recommendations.

Control lights and luminaires by photocell controls. For current less than or equal to 10 amperes, furnish a photocell switch. For current greater than 10 amperes, furnish a photocell switch operating a magnetic relay for switching the lighting circuit.

Testing and Demonstration Period

Before energizing any portion of the system, demonstrate that the conductor system is clear and free of all short circuits, open circuits, and unintentional grounds. Repair or replace faulty circuits.

After energizing the system, demonstrate to the CO that all electrical components work properly. Repair or replace faulty electrical components.

After completing electrical component tests, conduct a demonstration test for thirty (30) continuous calendar days. Adjust and correct any deficiencies in the system during the 30-day demonstration period. If any portion of the system is replaced or repaired, retest that portion of the system for an additional 30 calendar days.

Warranties, Guarantees, and Instruction Sheets

Deliver manufacturers' warranties, guarantees, instruction sheets, and parts lists to the CO at the final inspection.

Upon completion of the work, also submit as-built drawings showing all detailed changes from the original plans.

Relocations

Use materials equivalent to existing materials, unless present codes require different or improved materials. Existing materials may be salvaged and reused provided all materials an installation methods used meet the requirements of applicable codes and ordinances.



Furnishings and Civic Infrastructure

FURNISHINGS AND CIVIC INFRASTRUCTURE:

WASTE RECEPTACLES:

Multiple trash and recycling receptacle styles have been approved for use throughout the monumental core, dependent on location and agency. See the Monumental Core Streetscape Design Guidelines for more information on Interagency Working Group (IWG) approved receptacle types and locations.

NPS-Type Waste Receptacle Detail

Description: Waste receptacle with vertical steel members, tapered lid, and recessed bottom pedestal.

Example: Victor Stanley S-Series or IWG-approved equal

Reference: See *Monumental Core Streetscape Design Guidelines: Small-Scale Elements – Waste Receptacles* for additional information.

Example Photo:



Modified PADC Waste Receptacle

Description: Waste receptacle based on a design commissioned by the Pennsylvania Avenue Development Corporation with vertical and circular design motif.

Example: Canterbury Designs Pennsylvania Avenue model or IWG-approved equal

Reference: See *Monumental Core Streetscape Design Guidelines: Small-Scale Elements – Waste Receptacles* for additional information.

Example Photo:



Capitol Grounds Waste Receptacle

Description: Waste receptacle based on the PADC Waste Receptacle, with wide vertical steel slats and circular detailing surrounding opening.

Example: Victor Stanley RS-12 or IWG-approved equal

Reference: See *Monumental Core Streetscape Design Guidelines: Small-Scale Elements – Waste Receptacles* for additional information.

Example Photo:



Box Waste Receptacle

Description: Rain and pest-proof enclosed receptacle with optional compacting features.

Example: Big Belly receptacle or IWG-approved equal.

Reference: See *Monumental Core Streetscape Design Guidelines: Small-Scale Elements – Waste Receptacles* for additional information.

Example Photo:



BENCHES:

Multiple bench styles have been approved for use throughout the monumental core, dependent on location and agency. See the *Monumental Core Streetscape Design Guidelines* for more information on Interagency Working Group (IWG) approved bench types and locations.

NPS Bench

Description: ADA-compliant armless bench with black stained wood and metal legs and leg supports.

Example: National Mall and Memorial Parks Parkwide ADA Bench Redesign

Reference: See *Monumental Core Streetscape Design Guidelines: Small-Scale Elements – Benches* for additional information.

Example Photo:



Smithsonian Institution Bench

Description: Wood slat bench on ductile iron legs.

Example: Victor Stanley C-12 bench or IWG-approved equal

Reference: See *Monumental Core Streetscape Design Guidelines: Small-Scale Elements – Benches* for additional information.

Example Photo:



District Bench

Description: Black steel bench with steel seat members; steel members should run perpendicularly to the length dimension of the bench.

Example: Victor Stanley RB-28 or IWG-approved equal.

Reference: See *Monumental Core Streetscape Design Guidelines: Small-Scale Elements – Benches* for additional information.

Example Photo:



Pennsylvania Avenue Bench

Description: Custom designed PADC bench with wood slats and steel legs and leg supports; single or double sided.

Example: Pennsylvania Avenue Custom Bench

Reference: See *Monumental Core Streetscape Design Guidelines: Small-Scale Elements – Benches* for additional information.

Example Photo:



Victorian Bench

Description: Victorian-style wood slat bench on black iron legs with center iron support; wood slats run parallel to length of bench; Victorian iron scrolling on end arm rests.

Example: President's Park Ellipse Victorian Bench, or IWG-approved equal.

Reference: See *Monumental Core Streetscape Design Guidelines: Small-Scale Elements – Benches* for additional information.

Example Photo:



DRINKING FOUNTAIN:

Drinking Fountain

Description: Black steel accessible pedestal water fountain and bottle filling station

Example: MDF Model 10145SM or IWG-approved equal.

Reference: See *Monumental Core Streetscape Design Guidelines: Small-Scale Elements – Water Stations* for additional information.

Example Photo:



POST AND CHAIN:

Post And Chain

Description: Black steel tube pipe fence posts with cast iron acorn cap and black steel chain.

Example: NPS standard post and chain

Photo to include: to be added

Reference: See *Monumental Core Streetscape Design Guidelines: Small-Scale Elements – Post-and-Chain* for additional information.

Example Photo:



BICYCLE RACK:

U rack

Description: Black steel inverted U bicycle rack; rack should be surface mounted or set in-ground; rack should not be rail installed.

Example: Dero Hoop Rack or IWG-approved equal.

Reference: Reference: See *Monumental Core Streetscape Design Guidelines: Small-Scale Elements – Bicycle Racks* for additional information.

Example Photo:



PARKING PAY STATION:

Multi-Space Parking Pay Station

Description: Titanium-gray multi-space digital parking meter.

Example: Flowbird Pay and Display Meter

Reference: See *Monumental Core Streetscape Design Guidelines: Small-Scale Elements – Parking Pay Stations* for additional information.

Example Photo:



OTHER:

Electric Vehicle Charging Station

Reference: See *Monumental Core Streetscape Design Guidelines: Small-Scale Elements – Electric Vehicle Charging Stations* for additional information.

Fire Hydrants

Reference: See *Monumental Core Streetscape Design Guidelines: Small-Scale Elements – Fire Hydrants* for additional information.

Small-Cell Infrastructure

Reference: See *Monumental Core Streetscape Design Guidelines: Small-Scale Elements – Small-Cell Cross References* for additional information.





401 9th Street, NW Suite 500N ■ Washington DC 20004 ■ Phone: (202) 482-7200 ■ Email: info@ncpc.gov
■ <https://www.ncpc.gov/> ■ **NCPCgov**